

NANOPOSITIONERS

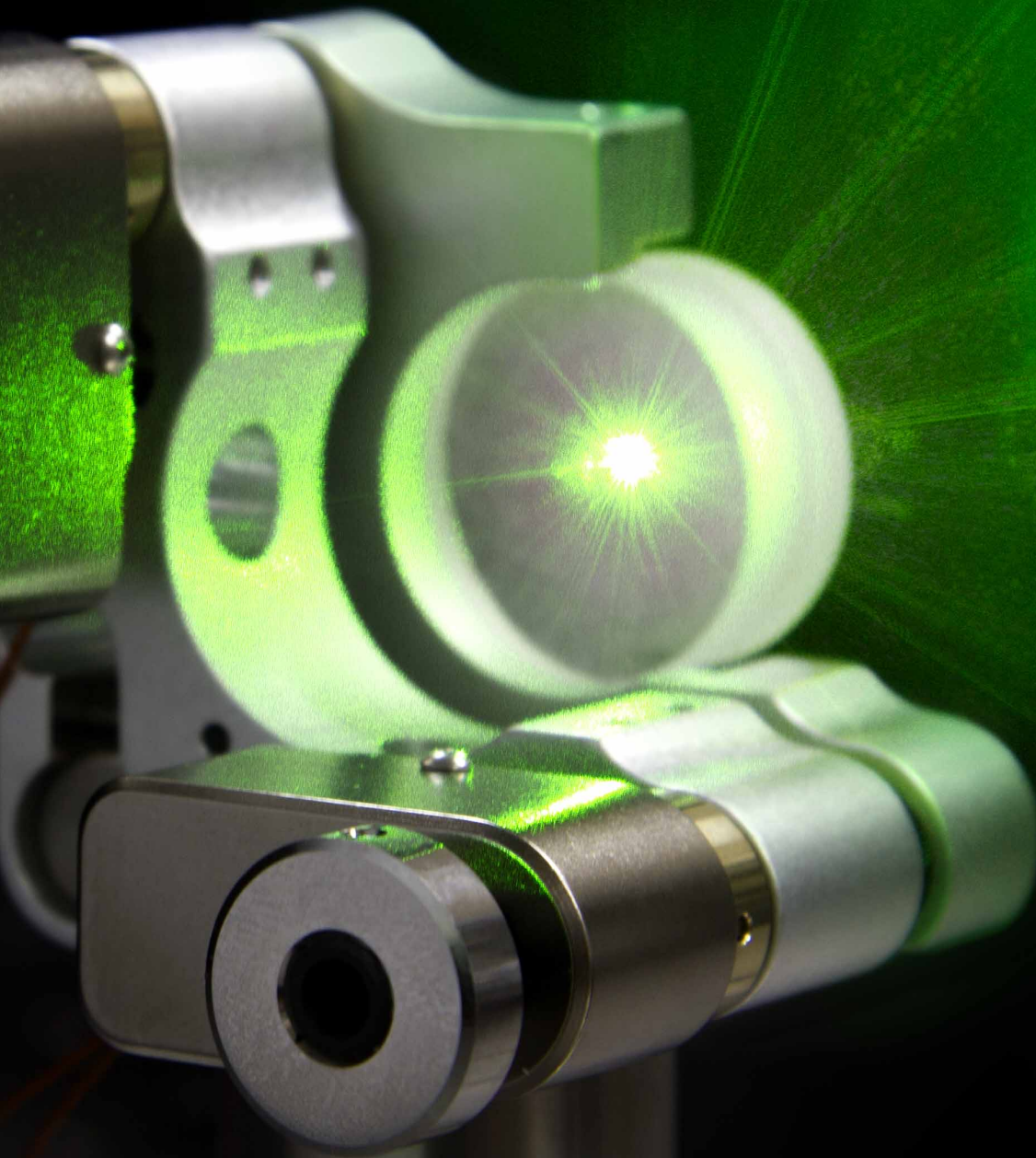

Picomotors™

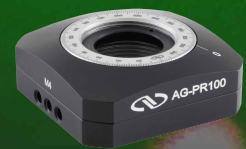

Agilis™



NanoPZ™



Piezo Stack

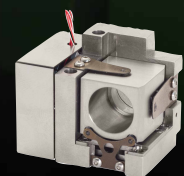

OEM

Nanopositioning Solutions

The effects of human operation limit the precision of many optical adjustments. In theory, it is possible to achieve adequate adjustment sensitivity with very fine mechanics. However, in practice, the lateral forces applied to a component during an adjustment often have an excessive effect, making alignments lengthy and frustrating. Also, many optical experiments are extremely sensitive to environmental factors and provide consistent results only when well shielded against external influences.

Our nanopositioner solutions are ideal devices for providing exceptional nanometer scale remote control for manual positioning stages and opto-mechanical components over large distances, hard-to-reach spaces and hazardous hands-off applications. Our exclusive design and our innovative piezo based technology allows a range of motion and stability that ensures nanometer scale of motion with minimal to no backlash.

The short list of applications of our nanopositioner solutions include: metrology, remote and automated beam steering, micropositioning, microscopy, wafer inspection, telecom components alignment, flow cytometry, and many more.

Newport also supplies corresponding controller and drivers from single to multi-axis units and from hand-held to full PC control. We utilize Newport exclusive plug-and-play controller technology that minimizes setup time and provides great ease of use.



Table of Contents



Picomotors™

Page 2

- Exceptional precision
- Set-and-forget stability with virtually no backlash
- Vacuum and Closed-Loop compatibility
- Integrated stage solutions

PICOMOTORS



Agilis™

Page 26

- Highly precise and repeatable incremental motion steps
- Innovative miniature encoder technology – CONEX
- Robust design for uninterrupted use and long life
- Ultra-compact – ideal for system integration

AGILIS



NanoPz

Page 37

- High reliability operation
- Fast speed and high load capacity
- Non-rotating tip
- No loss of position with removal of power; ideal for set-and-forget applications

NANOPZ



Piezo Stack

Page 40

- Precision parallelogram design minimizes beam offsets
- Piezoelectric translators in an ultra-compact package
- Closed-Loop option with strain gauge
- Integrated stage solutions

PIEZO STACK

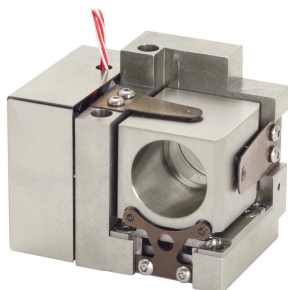

OEM Solutions

Page 49

- Quality systems
- Material qualification
- Mechanical design analysis
- Recognized leader

OEM

Simply Better™ Precision Motion Control

Picomotors™

When you need fine control of your laser alignment, linear stages, rotary stages, etc., New Focus™ has an innovative, reliable solution for you. Here we outline several reasons why our Picomotor™ actuators and motorized stages and mounts are optimum products.



How the Picomotor™ Actuator Works

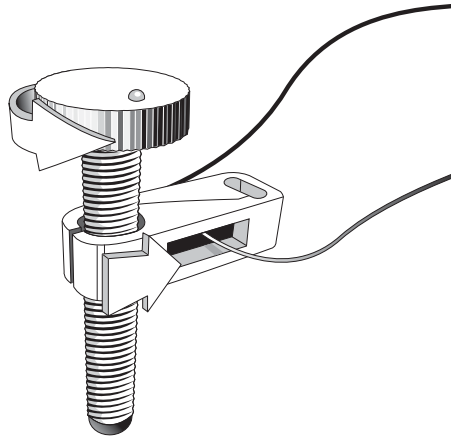

The patented design of the Picomotor actuator relies on the basic difference between dynamic and static friction. A graphic example of this is the “tablecloth trick,” in which a quick pull of the cloth leaves the dishes on the table (low dynamic friction), while a slow pull of the tablecloth ends up pulling the dishes off the table (high static friction and a big mess!). Our Picomotor actuator uses the same principle with a threaded jaw, similar to two halves of a split nut, clamped around a precision 80-pitch screw. One jaw is connected to one end of a piezoelectric transducer, and the other jaw is connected to the other end of the transducer. A slow electrical signal applied to the piezo slowly changes the length, causing the two jaws to slide in opposite directions. This slow sliding motion makes the screw turn (static friction). At the end of the transducer motion, a fast electrical signal quickly returns the jaws to their starting positions. Because of the screw’s inertia and low dynamic friction, it remains motionless, holding its position. Simply reversing the order of the fast and slow signals reverses the direction of rotation.

Easy-to-use, flexible controllers and drivers

Our Picomotor controller and drivers are modular. You can daisy-chain up to 31 drivers together with four channels each, so you can have a network of up to 124 standard Picomotor actuators or up to 62 Closed-Loop Picomotor actuators (two channels each). You have two interface options with the controller system: handpad or computer control. Alternatively, you may choose to use our TTL/Analog Picomotor Driver.

Exceptional precision

Our Picomotor actuators have a step size of <math><30\text{ nm}</math> per step, allowing for very small, controlled movements. In addition, we have closed-loop solutions offering excellent repeatability. Closed-loop, encoders versions are available for actuators, linear stages, and rotary stages.

Set-and-forget stability with virtually no backlash

The Picomotor actuator moves when voltage is applied to the piezo, changing its length and in turn moving the jaws which turn the screw (see earlier section for more detail on how the Picomotor actuator works). When no power is applied, the actuator does not move. You can feel confident that your set-up will stay put, even when you power down your system.

Vacuum compatibility













We have several solutions for motion control in vacuum or ultraclean environments. Our standard Picomotor actuators are offered in both vacuum (to 10^{-6} Torr) and UHV (to 10^{-9} Torr) versions. Both the Tiny Picomotor and Closed-Loop Picomotor actuators are available in vacuum versions. We also have the Picomotor actuator Ultra, which is designed for UHV and/or ultraclean environments.











Substantial force from a small package

With load capacity of 5 lbs (22N), our Picomotor actuators have a substantial push force. All this fits in a compact package. Our Tiny Picomotor actuator now offers up to 3 lbs (13N) of push force in an even smaller package size.

Picomotor™ Selection Guide

Description		Travel Range or Number of Motors	Minimum Incremental Motion	Model #	Page
Actuators					
	Picomotor Actuators	0.5"-2.0"	<30 nm	83xx	Pg. 5
	Tiny Picomotor Actuators	0.5"	<30 nm	835x	Pg. 6
	Vacuum and UHV-compatible Picomotor Actuators	0.5"-2.0"	<30 nm	83xx-V, 83xx-UHV	Pg. 7
	Vacuum-Compatible Tiny Picomotor Actuators	0.5"	<30 nm	835x-V	Pg. 7
	Closed-Loop Picomotor Actuators	0.5"	<30 nm	8310	Pg. 8
	Vacuum-Compatible Closed-Loop Picomotor Actuators	0.5"	<30 nm	8310-V	Pg. 9
Optical Mounts					
	Optical Mounts	2-3 motors	0.7 μrad	88xx	Pg. 10
	Large Aperture Mounts	2 motors	0.7 μrad	882x	Pg. 11
	Pint Sized Mounts	2 motors	1.5 μrad	888x	Pg. 12
	UHV Pint-Sized Center Mount	2 motors	1.5 μrad	8885-UHV	Pg. 12
	Stability Mounts	2 motors	0.7 μrad	8816-x	Pg. 13
	Vacuum Stability Mounts	2 motors	0.7 μrad	8817-x-V	Pg. 14
	Motorized Flipper Mount	90° flip	-NA-	889x	Pg. 15

Description	Travel Range or Number of Motors	Minimum Incremental Motion	Model #	Page
Stages				
 Rotary Stages	360°	0.2 mrad	8401	Pg. 16
 Closed-Loop Rotary Stages	360°	0.2 mrad	8410	Pg. 16
 Kinematic Stages	4-6 motors	<30 nm	80xx	Pg. 17
 UHV Kinematic Stage	5 motors	<30 nm	8081-UHV	Pg. 18
 Fiber Positioner	2 motors	<30 nm	8051	Pg. 18
 Gothic-Arch-Bearing Solutions	1-3 motors	<30 nm	9062, 9063	Pg. 19
 Compact Gothic-Arch-Bearing Integrated Motion-Control Solutions	1-2 motors	<30 nm	9061	Pg. 20
 Crossed-Roller-Bearing Integrated Motion-Control Solutions	1-3 motors	<30 nm	9066, 9067	Pg. 20
 Triple-Divide Integrated Motion-Control Solutions	1-3 motors	<30 nm	9064, 9065	Pg. 21
 Encoded Translation Stages	0.5"-1.0"	<30 nm	906x-COM-E	Pg. 22
Controllers and Drivers				
 Open-Loop Controller/Driver	-NA-	-NA-	8742	Pg. 23
 Closed-Loop Controller/Driver	-NA-	-NA-	8743-CL	Pg. 23
 Hand Control Pad for 874X	-NA-	-NA-	8758	Pg. 24
 PCB-Mountable Driver	-NA-	-NA-	8712	Pg. 24
Beam Stabilization				
 GuideStar II Controller	-NA-	-NA-	8783	Pg. 25
 GuideStar II Trigger Kit	-NA-	-NA-	8783-T	Pg. 25
 GuideStar II Camera Sensor	-NA-	-NA-	8784	Pg. 25

Picomotor™ Actuators



- < 30 nm resolution in a compact design
- Set-and-forget long-term stability
- Lifetimes of 1,000,000,000 steps
- Vacuum and Ultrahigh-Vacuum

From left to right: Models 8353, 8341, 8301, 8302, and 8303.

Picomotor actuators are ideal for motorizing fine-positioning stages and mounts. Use them with our stages and mounts or your own custom devices. They have better than 30-nm resolution with minimal backlash, and can exert a 5-lb (22-N) force. Moreover, they have exceptional longterm stability and the ability to hold their position with no power applied. These last two features make the Picomotor actuators unique and ideal for set-and-hold applications.

The standard sized shanks of the Models 830X and 832X let them fit into standard micrometer mounting holes. For rotation without translation, use Model 8341NF rotating shaft.

Use these Picomotor actuators with our Model 8742 Picomotor controller/driver or our 8712 Analog/TTL driver. – Contact us for custom configurations and volume pricing.

Model	8301NF	8302	8303	8321	8322NF	8341NF
Style	Standard	Standard	Standard	Metric	Metric	Rotating
Travel [in(mm)]	0.50 (12.7)	1 (25.4)	2 (50.8)	0.50 (12.7)	1 (25.4)	NA
Minimum Incremental Motion (nm)	<30	<30	<30	<30	<30	NA
Resolution- Angular (mrad) ¹	<0.6	<0.6	<0.6	<0.6	<0.6	<0.6
Axial Load Capacity (N)	22	22	22	22	22	NA
Mounting	0.375 in. (9.5 mm) Shank			M12 x 0.5 mm Thread		0.375 in. (9.5 mm) Shank
Connector Type	4-Pin	4-Pin	4-Pin	4-Pin	4-Pin	4-Pin
Cable Length [ft. (m)]	7 (2.1)	7 (2.1)	7 (2.1)	7 (2.1)	7 (2.1)	7 (2.1)

¹ Since these motorized components do not have internal encoders, repeatability is not specified or guaranteed. Step sizes can vary over 20% between the forward and backward directions.

Model 8302

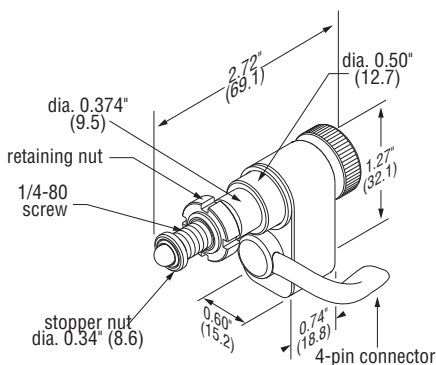

Model 8321

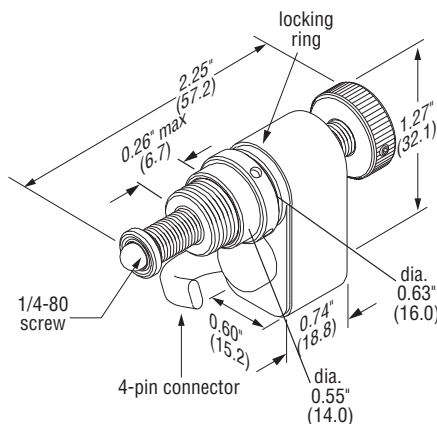

Model 8341

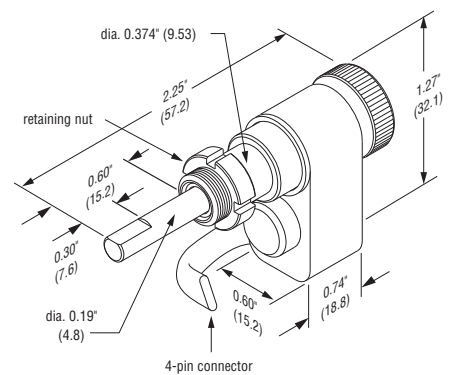

U.S. Patent #5,394,049 & #5,410,206

Tiny Picomotor™ Actuators

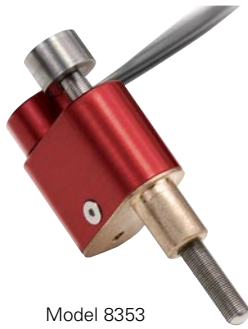

Model 8353

- < 30 nm resolution
- Ultra compact design
- Set-and-forget long-term stability
- Vacuum and Ultrahigh-Vacuum

Our Tiny Picomotor actuator is a smaller-sized version of our standard Picomotor actuators. We have improved the design so that it will meet even more of your compact-area needs.

The Tiny Picomotor actuator is ideal for moving small linear stages, like our Compact Gothic-Arch-Bearing stage. It is also integrated with some of our Pint-Sized mounts. The overall footprint is even smaller now; the cable exits from the side, similarly to our standard Picomotor actuators. For such a small device, it has an impressive pushing force (13 N).

With two mounting options, a standard 0.25" shank and a 1/4-40 thread version, it is straight-forward to incorporate it into your design. The Tiny Picomotor Actuator should be used with the 8742 Picomotor controller/driver or our 8712 Analog/TTL driver.

Model	8353	8354
Style	Tiny	Tiny
Travel [in(mm)]	0.50 (12.7)	0.50 (12.7)
Minimum Incremental Motion (nm)	<30	<30
Resolution- Angular (mrad) ¹	<0.6	<0.6
Axial Load Capacity (N)	13	13
Mounting	0.25 in. shank	1/4-40 Thread with retaining nut
Connector Type	4-Pin	4-Pin
Cable Length [ft. (m)]	7 (2.1)	7 (2.1)

¹ Since these motorized components do not have internal encoders, repeatability is not specified or guaranteed. Step sizes can vary over 20% between the forward and backward directions.

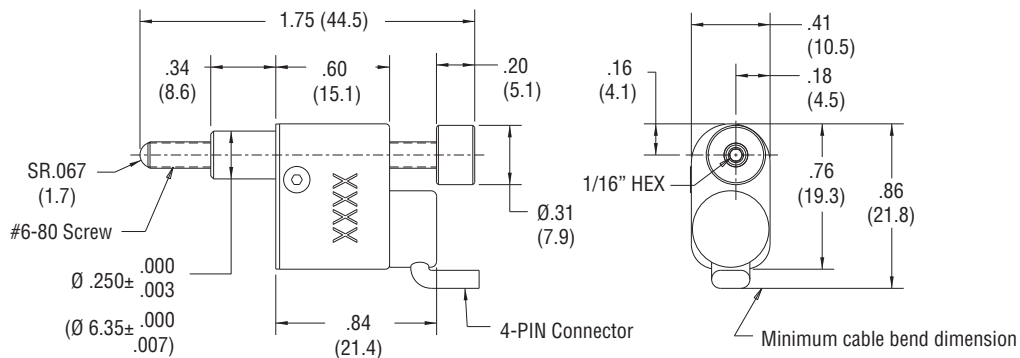

Vacuum and Ultra-High Vacuum Picomotor™ Actuators



From left to right: Models 8302-UHV, 8321-UHV, 8301-UHV, and 8341-UHV

- UHV version compatible to 10^{-9} Torr; vacuum version compatible to 10^{-6} Torr
- 1/2", 1", and 2" travel ranges
- Set-and-forget long-term stability
- Teflon or Kapton wires available

All our vacuum compatible and ultra-high vacuum compatible Picomotor actuators come with short, Teflon®-coated leads so you can make connections to your vacuum-chamber feedthrough. If, however, you are also working with X-rays or other high-radiation applications, we recommend ordering a version with Kapton®-coated wire extensions.

We've improved the specifications of our popular Picomotor actuators so that they can be used in either vacuum (10^{-6} Torr) or UHV (10^{-9} Torr) environments as well as for VUV/EUV applications. Ideal for beam-steering and scientific vacuum motion-control applications, these Picomotor actuators offer vacuum compatibility down to 10^{-9} Torr. As with our Picomotor actuators, these vacuum versions offer the same 30-nm resolution over the full travel along with excellent long-term stability and high stiffness—including the ability to maintain its set position even in the power off state.

As with all of our Picomotor actuators, these are easily incorporated into OEM designs for linear actuation as well as into optical mounts and stages for precision tip-tilt beam-steering adjustments.

Use these Picomotor actuators with our Model 8742 Picomotor controller/driver or Model 8712 Analog/TTL driver.

Vacuum Model	8301-V	8302-V	8303-V	8321-V	8322-V	8341-V	8353-V
Vacuum Compatibility				10^{-6} Torr			
Wire Lead Length ¹				1.75 in			
Wire Type (vacuum rated)				Teflon®			
UHV Model	8301-UHV	8302-UHV		8321-UHV		8341-UHV	
Vacuum Compatibility				10^{-9} Torr			
Wire Lead Length ¹				1.75 in			
Wire Type (vacuum rated)				Teflon®			
UHV-KAP Model	8301-UHV-KAP	8302-UHV-KAP		8321-UHV-KAP		8353-UHV	
Vacuum Compatibility				10^{-9} Torr			
Wire Lead Length				6 in			
Wire Type (vacuum rated)				Kapton®			

¹ We provide an additional 7 ft (2.1 m) of standard cable with each model
 Note: Remaining specs are same as standard versions

Closed-Loop Picomotor™ Actuator



Model 8310

- Built in rotary encoder for Closed-Loop operation
- All the benefits of our traditional Picomotor actuators
- Compact packaging enabling integration into our translation stages and most optical mounts

The Model 8310 closed-loop Picomotor actuator and Model 8743-CL Closed-Loop Picomotor driver are ideal for applications where Closed-Loop control is required. With an integrated rotary encoder and forward and reverse limit switches, this unique device offers the best attributes of the standard Picomotor actuator—<30-nm resolution, >5 lbs (22 N) of force along with set-and-forget long-term stability—with the added benefits of exceptional accuracy and $\pm 1\text{-}\mu\text{m}$ bi-directional repeatability over the entire half-inch travel range.

Choose between operating the Model 8310 Closed-Loop Picomotor actuator in closed-loop mode where it can hold a set position, or command it to move a specified distance. You can also choose between position- or velocity-profiled movement. Either way, when the actuator reaches its target location, the controller will adjust the motor to the precise requested encoder count and then stop motion. Even if you keep the servo loop enabled, the motor will only move in response to any system disturbances which cause rotation of the screw. Because the inherent resolution of the motor is finer than the resolution of the encoder, zero-count encoder error is always achieved. You can query the encoder to determine the rotation of the screw at any time.

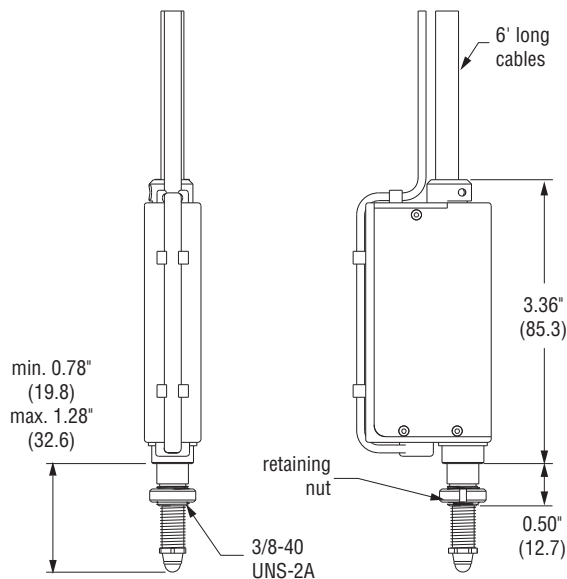

Model 8310

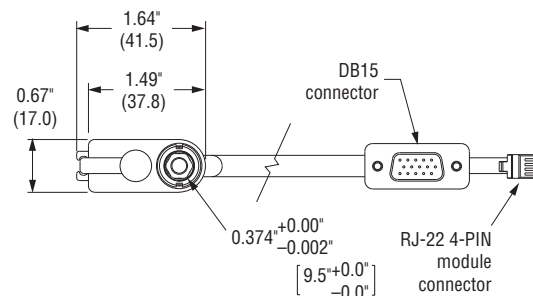

Model	8310
Minimum Incremental Motion (nm)	<30
Resolution- Angular (mrad)	<0.6
Axial Load Capacity (+Cx) (N)	22
Travel [in. (mm)]	0.50 (12.7)
Operating Temperature Range (°C)	10-40
Mounting	0.375 in. shank (9.5 mm shank)
Connector Type	One Each: 15-Pin D and 4-Pin RJ-22
Cable Length [ft. (m)]	6 (1.8)

Closed-Loop Vacuum Picomotor™ Actuator



Model 8310-V

- Compatible to 10^{-6} Torr
- All the benefits of our traditional Picomotor actuators
- Completely compatible with our Picomotor Controller/Drivers

This vacuum compatible Model 8310-V Closed-Loop Picomotor actuator is ideal for applications where Closed-Loop control is required in a clean environment. Just like the Model 8310 Closed-Loop Picomotor actuator, Model 8310-V offers an integrated rotary encoder and home, forward, and reverse limit switches. It combines the best attributes of our vacuum-compatible Picomotor actuator— <30 -nm resolution, >5 lbs (22 N) of force along with set-and-forget long-term stability and vacuum compatibility—with the added benefits of exceptional accuracy and ± 1 - μm bi-directional repeatability over the entire travel range.

Use the Model 8743-CL Closed-Loop Picomotor controller/driver to control the Model 8310-V Closed-Loop Picomotor actuator. Our Picomotor controller/driver provides the ability to build a system incorporating multiple standard Picomotor actuators and one or more Closed-Loop Picomotor actuator at the same time on the same control network.

The closed-loop Picomotor actuator offers <1 - μm repeatability when approaching a target encoder count from any direction, <0.5 -micron repeatability when approaching from a single direction, and 63.5-nm encoder resolution. (The actual inherent motor step size is considerably smaller—approximately 20 nm.)

Vacuum Model	8310-V
Minimum Incremental Motion (nm)	<30
Resolution- Angular (mrad)	<0.6
Axial Load Capacity (+Cx) (N)	22
Travel [in. (mm)]	0.50 (12.7)
Operating Temperature Range ($^{\circ}\text{C}$)	10-40
Mounting	0.375 in. shank (9.5 mm shank)
Connector Type	One Each: 15-Pin D and 4-Pin RJ-22
Cable Length [ft. (m)]	6 (1.8)
Vacuum Compatibility	10^{-6} Torr
Wire Type (vacuum rated)	Teflon
Wire Lead Length	1.75 in

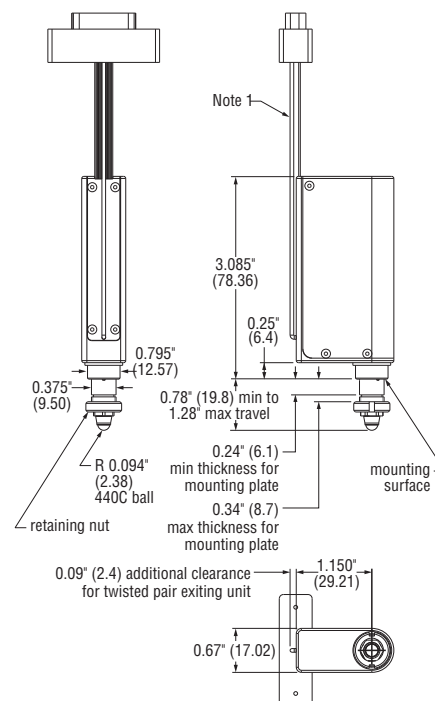

1. Cables shown are 19" long with a PEEK 15 PIN miniature Sub-D Connector. Sensor wire is a 11 Conductor Teflon Ribbon Cable and Picomotor wire is a shielded 2 wire twisted pair.

Picomotor™ Motorized Optical Mounts



- Compact design
- 0.7- μ rad resolution
- Integrated solutions

Left to right: Models 8809, 8853 and 8807

Our Model 88XX motorized optical mounts combine the precision of our standard mounts with the resolution of our Picomotor actuators to provide the ultimate in precision motorized optical alignment. The compact Picomotor actuator housing adds only 0.75" (19.1 mm) to the overall thickness of these mounts.

For an affordable solution for motorized tip and tilt alignment, use the Model 8807 motorized version of our popular 1" center mount. Unlike our other motorized mounts, this mount has Picomotor actuators on just two of its three adjustment axes.

Model	8806	8808	8807	8809	8812	8852	8853	8854
Optic Diameter [in. (mm)]	Blank	0.5 (12.7)	1.0 (25.4)	1.0 (25.4)	1.0 (25.4)	2.0 (50.8)	2.0 (50.8)	1.0-2.0 (25.4-50.8)
Motorized Axes	3	3	2	3	3	3	3	3
Connector Type	4-Pin	6-Pin	4-Pin	6-Pin	6-Pin	6-Pin	6-Pin	6-Pin
Type	Blank Plate Mount-	Corner Mount	Center Mount	Corner Mount	Gimbal Mount	Corner Mount	Gimbal Mount	Opti-Claw Mount
Angular Range (°)	±4							
Resolution- Angular (μ rad)	0.7							
Cable Length [ft. (m)]	7 (2.1)							
Operating Temperature Range (°C)	10-40							
Thread Type	8-32 (M4) Thru							

Model 8807

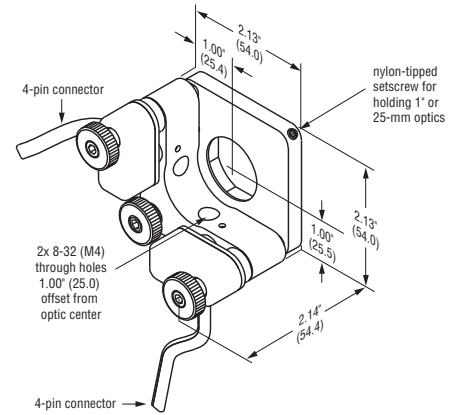

U.S. Patent #5,410,206

Large Aperture Motorized Mounts



- Kinematic mechanism
- Θ_x , Θ_y adjustments
- Angular resolution $<0.7 \mu\text{rad}$
- Set-and-forget long-term stability
- Clear edge or center mount

The 882X series is now available in aperture versions 1.0, 2.0, 3.0, or 4.0 in diameter optics in a center mount. With the thick front and rear plates, carbide seats, and optimized stiff springs, it provides for smooth, reliable motorized adjustment while maintaining a high level of thermal and mechanical stability. The Picomotor offers the additional advantage of motorized positioning of $<0.7 \mu\text{rad}$ resolution or just utilizing the integrated knobs for quick, manual adjustment of all axes. The 8821, 8822, and 8823 versions with the clear quadrant designs offer a versatile positioning system for mounting 2.0 and 3.0 in mirrors while providing greater beam access. The 8822-AC, 8823-AC, and 8824-AC versions with its low-distortional axial clamping technique minimizes mount-induced wavefront distortions.

Model	8821	8821-L	8822	8822-AC	8822-L	8823	8823-AC	8824-AC
Optic Diameter [in. (mm)]	1.0 (25.4)	1.0 (25.4)	2.0 (50.8)	2.0 (50.8)	2.0 (50.8)	3.0 (76.2)	3.0 (76.2)	4.0 (101.6)
Type	Clear Edge Center Mount	Clear Edge Center Mount	Clear Edge	Center Mount	Clear Edge	Clear Edge	Center Mount	Center Mount
Angular Range ($^\circ$)	± 5	± 5	± 5	± 5	± 5	± 3.5	± 3.5	± 3.5
Motorized Axes	2							
Connector Type	4-Pin							
Resolution- Angular (μrad)	0.7							
Cable Length [ft. (m)]	7 (2.1)							
Operating Temperature Range ($^\circ\text{C}$)	10-40							
Thread Type	8-32 (M4) Thru							
Dimension A [in. (mm)]	2.19 (55.6)	2.19 (55.6)	2.81 (71.5)	2.94 (74.6)	2.81 (71.5)	3.81 (96.9)	3.82 (97.2)	4.82 (122.6)
Clear Aperture B [in. (mm)]	1.0 (25.4)	1.0 (25.4)	2.0 (50.8)	1.88 (47.6)	2.0 (50.8)	3.0 (76.2)	2.81 (71.4)	3.75 (95.3)

UHV Model	8821-UHV	8821-AC-UHV	8821-L-UHV	8822-UHV	8822-AC-UHV	8822-L-UHV	8823-UHV	8823-AC-UHV	8824-AC-UHV
Vacuum Compatibility	10^{-9} Torr								
Wire Type (vacuum rated)	Kapton [®]								

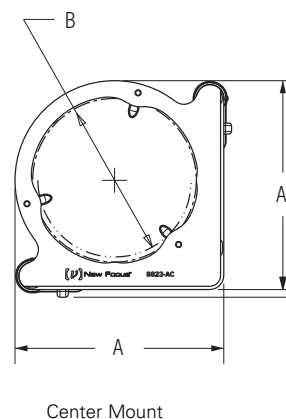
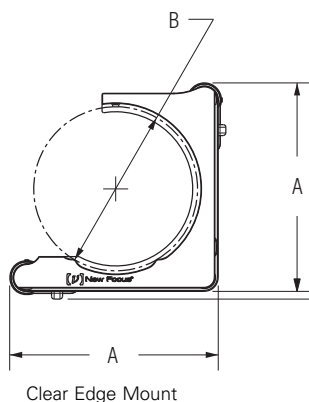

Pint Sized Picomotor™ Optical Mounts



Model 8885

- Motorized for hands-off alignment
- Angular resolution of 1.5 μ rad
- Compact and compatible

By adding our Tiny Picomotor actuators to our popular Pint-sized mirror mounts, you get 1.5- μ rad resolution in an extremely small package. These motorized mounts eliminate problems usually associated with small systems where there is little room to make adjustments and there is high sensitivity to adjustments by hand. The two Picomotor actuators that allow remote adjustment of the tip and tilt axes add only 0.5" of depth to these mounts. These Pint-sized mounts are fully compatible with the posts, pedestals, and mounts you already own.

Model	8885	8886	8887
Type	Pint Sized Center Mount	Pint Sized Corner Mount	Pint Sized Corner Mount
Optic Diameter [in. (mm)]	0.5 (12.7)	0.5 (12.7)	1.0 (25.4)
Motorized Axes		2	
Resolution- Angular (μ rad)		1.5	
Angular Range (°)		± 4	
Connector Type		4-Pin	
Cable Length [ft. (m)]		7 (2.1)	
Operating Temperature Range (°C)		10-40	
Thread Type		#8 or M4 Counterbore	

Pint Sized UHV Picomotor™ Optical Mount

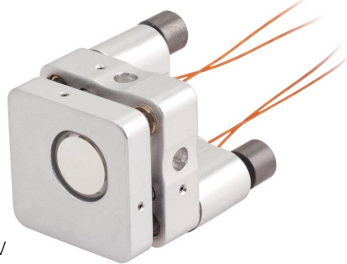

Model 8885-UHV

UHV Model	8885-UHV
Vacuum Compatibility	10^{-9} Torr
Wire Type (vacuum rated)	Kapton

Model 8885

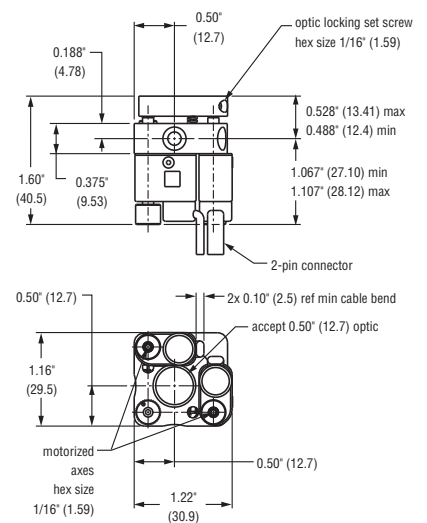

U.S. Patent #5,410,206

Picomotor™ Stability Series



Model 8816-6

- Ultrastable
- Unique optic-retention system for minimizing distortion of the wavefront

The Model 8816-6 combines the stability of our Stability™ mounts with the precision and stiffness of our Picomotor actuators to provide the ultimate in precision motorized optical alignment. The compact Picomotor actuator housing adds only 0.75" (19.1 mm) to the overall thickness of these mounts. And, with two standard Picomotor actuators to provide tip and tilt adjustment, you have complete remote control. The unique optic-retention system minimizes wavefront distortion of the mounted optic as well as maximizes overall mechanical stability. Mirror installation and removal is simple and fast, requiring no adhesives.

Model	8816-6	8816-8
Mirror Thickness (mm)	6	8
Optic Diameter [in. (mm)]		1.0 (25.4)
Clear Aperture [in. (mm)]		0.9 (22.8)
Motorized Axes		2
Resolution- Angular (μrad)		0.7
Angular Range (°)		±4
Connector Type		4-pin RJ-22
External Cable Length [ft. (m)]		7 (2.1)
Operating Temperature Range (°C)		10-40
Thread Type		8-32 and M4

Model 8816

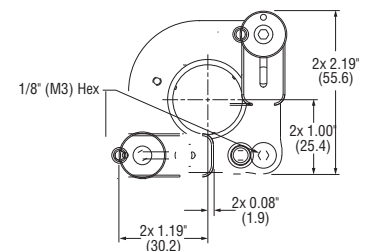
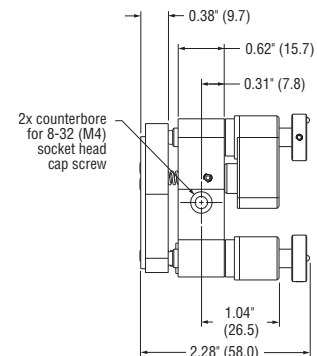
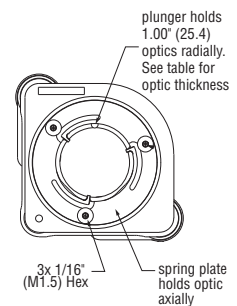

Stability™ Vacuum Compatible Motorized Optical Mount



Model 8817-6-V

- Models 8817-6-V and 8817-8-V Ultraclean Stability mounts are vacuum compatible to 10⁻⁶ Torr

The Model 8817-6-V is the vacuum-compatible version of the Model 8816. It offers ultraclean materials and components along with vacuum-compatible Picomotor actuators. Two “-V” vacuum-compatible Picomotor actuators provide full remote-control tip and tilt adjustment. Like all our vacuum-compatible products, the Model 8817-V is characterized using standard Gas Chromatography-Mass Spectrometry analysis (GCMS). It has been measured to outgas less than 0.1 ppm of volatile mass at 85 °C over three hours. Mass spectrograms detailing the exact outgassing compounds are available on request.

Model	8817-6-V	8817-8-V
Mirror Thickness (mm)	6	8
Optic Diameter [in. (mm)]		1.0 (25.4)
Clear Aperture [in. (mm)]		0.9 (22.8)
Motorized Axes		2
Resolution- Angular (μrad)		0.7
Angular Range (°)		±4
Connector Type		4-pin RJ-22
External Cable Length [ft. (m)]		7 (2.1)
Operating Temperature Range (°C)		10-40
Thread Type		8-32 and M4
Vacuum Compatibility		10 ⁻⁶ Torr
Wire Type (vacuum rated)		Teflon-Coated
Wire Length		1.75 in.

Model 8817-V

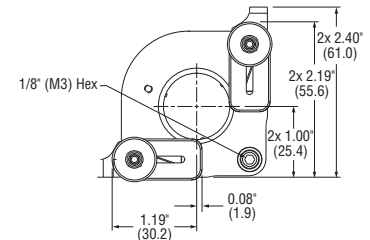
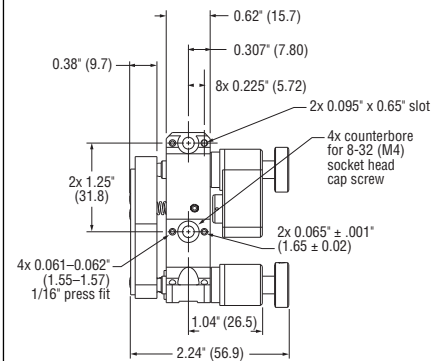
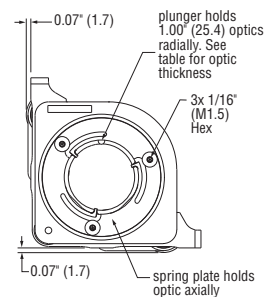

U.S. Patent #5,410,206

Motorized Flipper Optical Mounts



Model 8892-K

- Flip-to-flip repeatability to better than 25 μ rad
- Patented design
- Fast and stable

Remotely flip an optic in and out of your beam path with a transit time of less than half a second. Originally designed for demanding commercial applications, Model 8892-K motorized Flipper mount offers excellent stability and repeatability. Optic tilt is adjusted with our precision 80-pitch screws, and locking nuts preserve your settings during flips. The Flipper mount's included handpad lets you control it from a distance with your thumb, or you can control it even more remotely via its TTL interface.

Model 8893-K

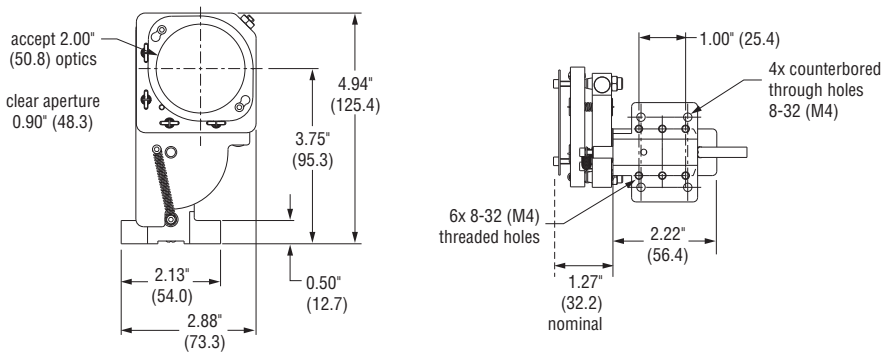

Model 8893-K

Model 8892-K

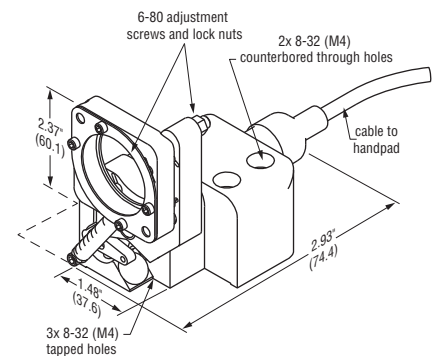

Model	8892-K (-M)	8893-K (-M)
Optic Diameter [in. (mm)]	1.0 (25.4)	2.0 (50.8)
Angular Range (°)	± 2	± 2
Connector Type	4 Pin	4 Pin
Type	Flipper Mount	Flipper Mount
Thread Type	8-32 (M4)	8-32 (M4)

Picomotor™ Rotary Stage



Model 8401

- 0.011° resolution
- Ideal for remotely rotating polarizers and wave plates
- Convenient 1" adapter included

With a resolution better than 0.2 mrad and an overall thickness of just 0.63" (16.0 mm), our compact stainless-steel motorized rotary stages can be used for a number of applications, including positioning wave plates and polarizers .

Each rotary stage includes an adapter for mounting components with a 1" (25-mm) diameter. For motorized beam-steering applications, use our 45° adapters PN 9922. If positional repeatability is important to you we recommend our 8410 Closed Loop version.

The 8410 Closed-Loop Picomotor Rotary Stage includes a rotary encoder for superior position feedback for rotational accuracy. This product provides microradian precision and continuous 360° rotation. Each stage comes complete with an adapter for mounting components with a 1 in. (25-mm) diameter. For motorized beam-steering applications, use our 45° adapters.

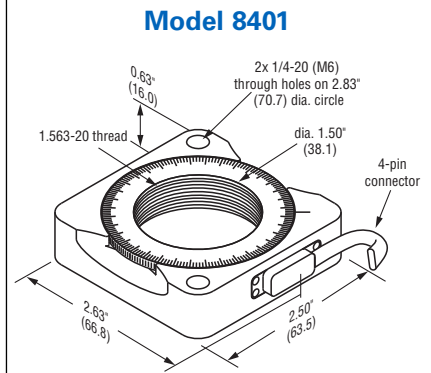

Model 8401

Model	8401 (-M)	8410
Resolution- Angular (mrad)	<0.2	0.2
Load Capacity [lb (N)]	1 (4.4)	1 (4.4)
Maximum Speed (°/sec)	1-2	1-2
Mounting	8-32 thread (M4)	8-32 thread
Connector Type	4 Pin	15-Pin in HD SUB

Closed-Loop Picomotor Rotary Stage



Model 8410

Multi-Axis Kinematic Alignment Stages

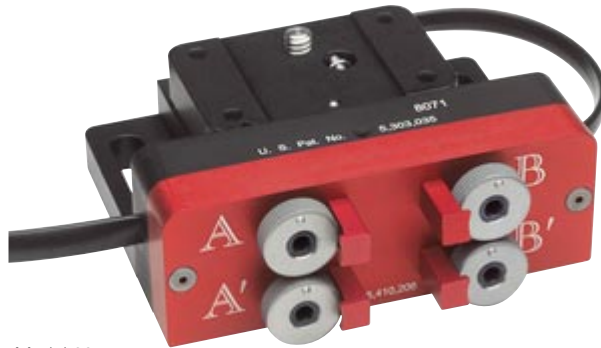

Model 8071

- <30-nm resolution
- 4- and 5-axis aligner - easily align modulators and isolators
- 6-axis aligner - ideal for semiconductor wafer alignment

These multi-axis positioners increase the utility of our popular kinematic stages by motorizing each of the axes. The addition of Picomotor actuators to each stage allows remote high-resolution (<30-nm) adjustment of various combinations of X, Y, Z, Θ_x , and Θ_y . The four-axis and five-axis aligners are ideal for positioning modulators or isolators and for coupling light into waveguide devices. The six-axis aligner is ideal for semiconductor-wafer alignment.

Model 8081

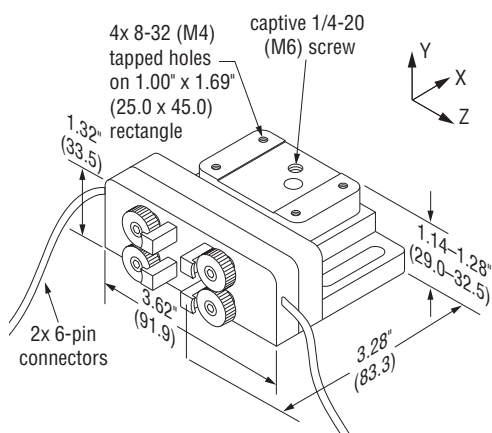

Model 8071 shown.

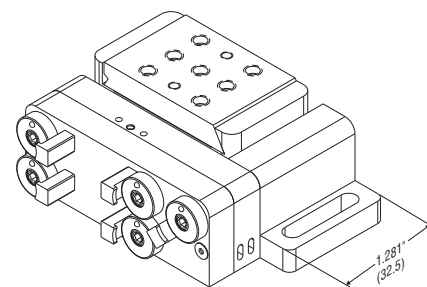

Model 8081 shown.

Model 8081-UHV

Our popular 8081 XYZ Θ_x Θ_y Motorized Five-Axis Tilt Aligner which increases the utility of our popular kinematic stages by motorizing each of the axes can now be used in UHV environments (10^{-9} Torr) as well as for VUV/EUV applications. The Picomotor actuators for each stage allows better than <30 nm remote high-resolution adjustment of various combinations of X, Y, Z, Θ_x , and Θ_y . With its minimal backlash, it is excellent for long term stability and high stiffness. The 8081-UHV has been tested and measured to outgas levels less than 5ppm of volatile mass at 85 °C over three hours. Mass Spectrograms detailing the exact outgassing compounds are available upon request. 8-32 and 1/4-20 tapped holes.

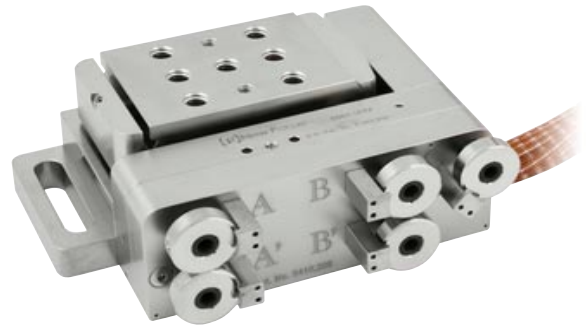

Model 8081-UHV

Model	8071 (-M)	8081 (-M)	8082 (-M)	8095 (-M)	8081-UHV (8081M-UHV)
Motorized Axes	4	5	5	6	5
Travel Range (mm)	3	3	3	3	X=5, Y&Z=3
Travel, Angular (°)	8	8	8	4	$\Theta_x=8, \Theta_y=10$
Minimum Incremental Motion, Linear (nm)	<30	<30	<30	<30	<30
Resolution- Angular (μ rad)	$\theta_x, \theta_y \leq 0.7$	$\theta_x, \theta_y \leq 0.7$	$\theta_x, \theta_y \leq 0.7$	$\theta_x, \theta_y, \theta_z \leq 0.2$	$\theta_x, \theta_y \leq 0.7$
Load Capacity [lb (N)]	3 (13)	3 (13)	3 (13)	3 (13)	3 (13)
Operating Temperature Range (°C)	10-40	10-40	10-40	10-40	10-40
Connector Type	6-pin Connectors (2)	6-pin Connectors (2)	6-pin Connectors (2)	4-pin Connectors (6)	DB15 Female
Thread Type	8-32 (M4)	8-32 and 1/4-20 (M4 and M6)	8-32 and 1/4-20 (M4 and M6)	1/4-20 (M6)	8-32 and 1/4-20 (M6)
Vacuum Compatibility	NA	NA	NA	NA	10^{-9} Torr

Motorized Fiber Positioners



Model 8051

- Unique flexure design
- Tiny version of single-mode-fiber aligner
- <0.1mm resolution

By motorizing our XY fiber positioners, we've improved their resolution from 1.0 μ m to finer than 0.1 μ m. Combining one of these stages with our Model 9092 coupler body and clamp gives you a good motorized multimode-fiber positioner.

Model	8051 (-M)
Motorized Axes	X, Y
Minimum Incremental Motion, Linear (nm)	<30
Maximum Speed (mm/min)	1
Operating Temperature Range (°C)	10-40
Connector Type	6 Pin
Thread Type	8-32 (M4)

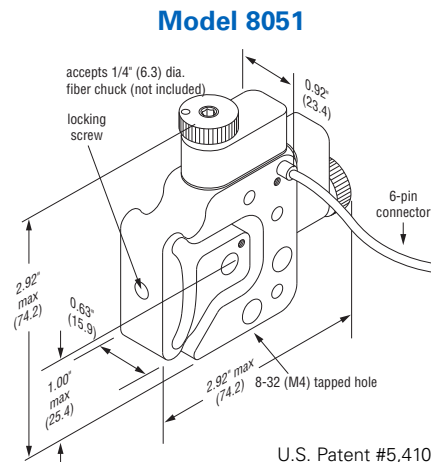

U.S. Patent #5,410,206

Gothic Arch Bearing Picomotor™ Linear Stages

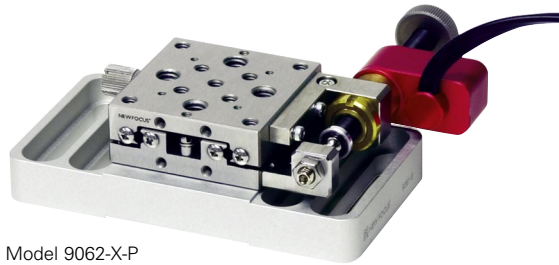

Model 9062-X-P

- True set-and-forget long-term stability—these actuators stay put
- Motorized and manual configurations
- Easily integrated with driver kit

We've incorporated our Picomotor actuators with our gothic-arch-bearing translation stages to achieve the ultimate in stability and rigidity along with remote-control operation. These motorized stages offer stainless-steel construction and thumbscrew locks. They are ideal for demanding applications in the laboratory, OEM, or on the manufacturing floor. Gothic-arch bearings offer the smooth motion of ball bearings but high stiffness and repeatability. The unique gothic profile provides increased contact area so that the load and momentum are more evenly distributed.

Model 9062-XY-PP

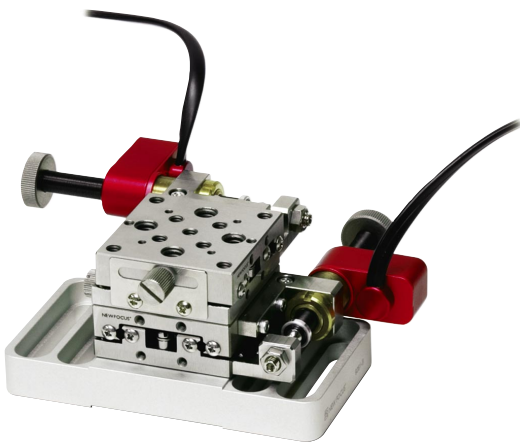

Model 9062-XYZ-PPP



Model	9061	9062	9063	9064	9065	9066	9067
Bearings	Gothic Arch Bearings	Gothic Arch Bearings	Gothic Arch Bearings	Ball Bearings	Ball Bearings	Crossed Roller Bearings	Crossed Roller Bearings
Travel Range (mm)	5	12.7	25.4	25.4	12.7	12.7	25.4
Minimum Incremental Motion, Linear (nm)				<30			
Operating Temperature Range (°C)				10-40			
Connector Type				4-Pin			
Cable Length [ft. (m)]				7 (2.1)			
Thread Type	8-32				8-32 and 1/4-20		

Vacuum Model	9066-V	9067-V
Vacuum Compatibility	10 ⁻⁶ Torr	10 ⁻⁶ Torr

Add -M to Model Number for Metric version.

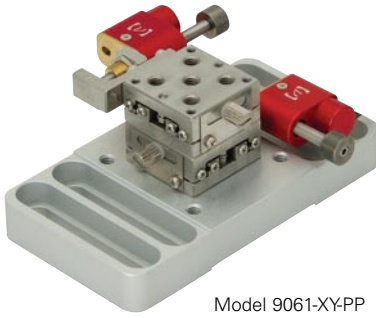

Model 9061-XY-PP

Compact Gothic-Arch Bearing Picomotor™ Linear Stages

We've incorporated our Tiny Picomotor actuators with our compact gothic-arch-bearing translation stages to achieve the ultimate in stability and rigidity along with remote-control operation. Please note that the Tiny Picomotor is only recommended for driving XY axis of our Gothic arch bearing stages due to the lower force limit compared with our regular Picomotor.



Model 9066-XYZ-PPN

Crossed Roller Bearing Picomotor Translation Stages

We've incorporated our Picomotor actuators with our crossed-roller-bearing translation stages to meet your demanding photonics applications. These crossed-roller-bearing motorized stages provide smooth and accurate positioning for critical optical alignment applications such as fiber alignment and high-stability positioning in laser systems. To ensure accurate linear travel, the stages use thermally matched hardened-steel, crossed-roller bearing and high-precision reference surfaces.



Model 9066-XYZ

Crossed Roller Bearing Vacuum Compatible Picomotor Translation Stages

Order the 9066 or 9067 Vacuum Compatible Stages with the 830X-V to integrate yourself for a vacuum compatible motorized translation stage.

Triple-Divide Picomotor™ Translation Stages



Model 9065-X-P

- Aluminum ball-bearing design—regular and Pint-sized versions
- Stability and orthogonality assured
- Easily integrated with driver kit

We've incorporated our Picomotor actuators with our Triple Divide translation stages to meet your laboratory applications. The Triple Divide motorized translation stage system is based on the unique e•z•trac™ rail system and delivers the stability of an integrated stage but is effortlessly adaptable and easy to use. Because of its modularity, these stages are extremely economical.

Model 9065-XY-PP



Model 9065-XYZ-PPP



How to Specify an Integrated Motorized Stage

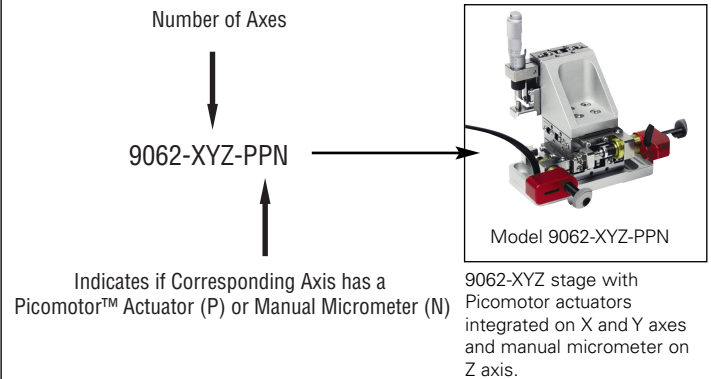

When ordering, specify which axis or axes you wish motorized with a "P" in the model number for Picomotor actuator, and "N" for manual micrometer. Mix and Match Picomotors and Actuators for your application.

Optically Encoded Stainless-Steel Translation Stages

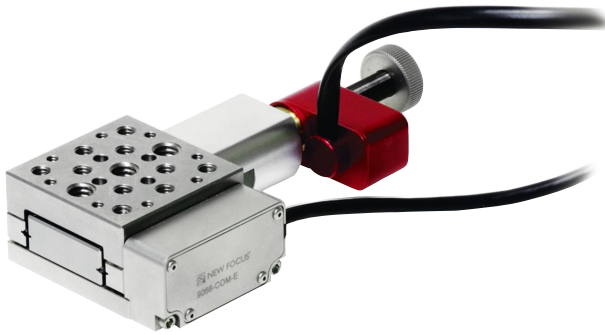

- Easily integrated with Picomotor™ actuators
- Linear optical encoder with 80-nm resolution
- Compatible with other stainless-steel crossed-roller-bearing translation stages

Model 9066-COM-E stage with a Picomotor actuator.

In response to customer demand, we're offering these linear, stainless-steel, crossed-roller-bearing translation stages with linear optical encoders so that you can build your own closed-loop Picomotor actuated stage. Use these stages with their integrated encoders and your choice of our many Picomotor actuators and you'll be able to accurately measure where you are and where you need to be. These encoders are compatible with the Model 8743-CL closed loop controller/driver.

Model 9067-COM-E

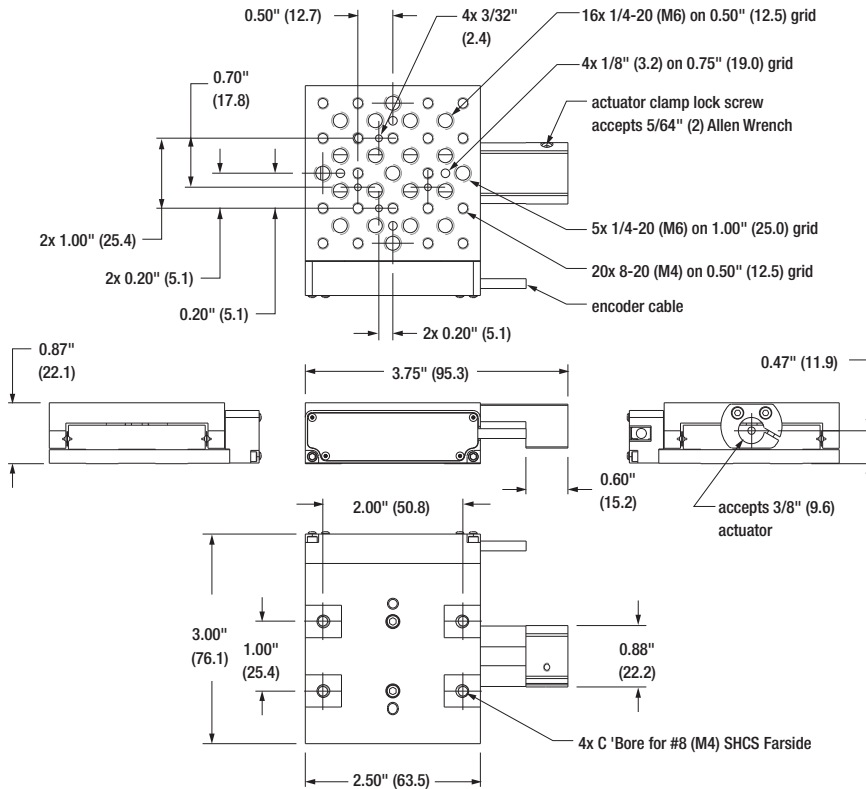

Model	9066-COM-E (-M)	9067-COM-E (-M)
Motorized Axes	X	X
Travel Range [in. (mm)]	0.5 (12.7)	1.0 (25.4)
Resolution (nm)	80	80
On-Axis Accuracy (µm)	3	3
Bearings	Crossed Roller Bearings	Crossed Roller Bearings
Motor/Encoder Type	Linear Optical	Linear Optical
Thread Type	8-32 and 1/4-20 (M4 and M6)	8-32 and 1/4-20 (M4 and M6)

Picomotor™ Controller/Drivers

Open-Loop Picomotor Controller/Driver Module



- 4-axis open-loop control and 2-axis closed-loop control
- Innovative Picomotor auto-detection technology
- Embedded dynamic HTTP server
- LabVIEW™ and Windows™ DLL support

Open-Loop Picomotor Controller / Driver Module – 4 Channels

The model 8742 is a 4-axis Open-Loop Picomotor controller/driver that provides a compact and low cost solution for driving New Focus Open-Loop Picomotor products.

It is a single-box solution that can be manually controlled with the New Focus 8758 hand control pad or computer controlled via USB, RS-485, or Ethernet communication interfaces using Newport Motion Control Language (NMCL) command set. These interfaces are well supported via Windows DLL, sample LabVIEW VIs, and intuitive graphical user interface (GUI) Windows application with device auto-discovery feature.

Closed-Loop Picomotor Controller/Driver Module

Model 8743-CL is a 2-axis Closed-Loop Picomotor controller/driver that provides fine tuning, absolute positioning, compact and low cost solution for driving New Focus Closed-Loop Picomotors products.



Each model 8743-CL controller/driver has two 4-pin RJ-22 single output ports and two 25-pin D connector for the encoder signal that can be used with any single-channel Closed-Loop Picomotor actuator at any given time.

Model	8742	8743-CL
Number of Channels	4	2
Maximum Pulse Rate	Up to 2 kHz	
Input Voltage (VDC)	12 (Nominal), 10.5 to 14.5	
Interface	10/100 Ethernet, USB 2.0, RS-485	
Power Consumption	11 Watts @ 2 kHz Sustained Speed kW, 2 Watts Idle	
Size [in. (mm)]	5.45 x 3.61 x 1.02 (148.3 x 91.7 x 25.8)	
Operating Temperature (°C)	0 to 65	
Storage Temperature (°C)	-40 to 95	
Weight [lb (g)]	0.6 (272)	

Picomotor Controller/Driver Kits

The 8742-4-KIT Four-Axis Picomotor Controller/Driver Module Kit and 8743-CL-2-KIT Two-Axis Closed-Loop Picomotor Controller/Driver Module Kit have everything you need to get started quickly. We've bundled our picomotor controller/driver and accessories together to provide a simple-to-use driver kit. Just plug in the included power supply and you're ready to go.



Model 8742-4-8821-RL

We've bundled our picomotor controller/driver and our ClearEdge picomotor mirror mounts together to provide a simple kit to get you started quickly. Just mount the ClearEdges, plug it into the driver and you're ready to go.

Kit includes:

- (x1) Model 8742 module and software
- (x1) Model 8745-PS power supply
- (x1) Model 8745-USB-CBL USB cable
- (x2) Model 8821 (-L and/or -R) ClearEdge picomotor mounts



Model 8743-CL-2-KIT

Kit includes:

- (x1) Model 8743-CL module and software
- (x1) Model 8745-PS power supply
- (x1) Model 8745-USB-CBL USB cable

Picomotor™ Hand Control Pad



Model 8758

The 8758 is a robust and fully functional multi-axis hand control device for controlling your Picomotor actuator products. This hand control pad facilitates local (non-computer) control of Picomotor positioners connected to the 8742 and/or 8743-CL Picomotor controller/drivers. It is a perfect solution when you need to run a quick test or just want a straightforward handheld controller device.

Model	8758
Interface	USB 2.0
Number of Drivers	31 Drivers
Cable Length (m)	3
Variable Speed Jog Control	Yes
Single Step Control	Yes
On/Off Switch	Yes
Axis per Controller/Driver	4 axis for 8742, 2 axis for 8743-CL

PCB-Mountable Driver

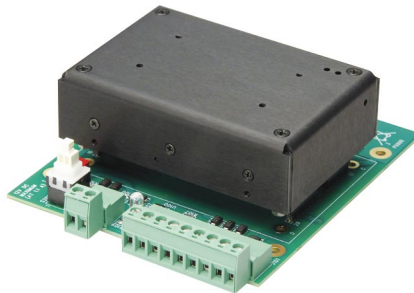

We designed the Model 8703 single-axis Picomotor driver for those of you who have asked us for a Picomotor driver that interfaces through TTL or analog signals. This redesigned driver is based upon our Model 8712 OEM driver, but comes on its own interface board and with connectors so you can easily interface with it and build it into your device, instrument, or laboratory setup. The Model 8704NF 12-V power supply is specifically for use with this driver.

NOTE: The Model 8703 driver module requires an external power supply (Model 8704 recommended), and is not compatible with the Intelligent Picomotor modules or their accessories.

Model	8712	8703
Number of Channels	1	1
Maximum Pulse Rate	2 kHz (25 °C, continuous operation)	2 kHz (25 °C, continuous operation)
Input Voltage	10 to 16 V (12 V nominal)	10-12 V
Interface	Pins for PCB Mounting	Input: 9-Pin Phoenix MSTBA Output: RJ-11 Phoenix 3-Position Terminal Block
Power Consumption	7.5 W @ 1-kHz Sustained Speed	7.5 W @ 1-kHz Sustained Speed
Size [in. (mm)]	3.75 x 2.53 x 1.09 (95.5 x 64.3 x 27.7)	4.62 x 4.09 x 1.63 (117.3 x 104 x 41.4)
Operating Temperature (°C)	0 to 65	0 to 65
Storage Temperature (°C)	-40 to 95	-40 to 95
Weight [lb (g)]	0.163 (74)	0.163 (74)

GuideStar™ II Laser Beam Steering Correction System

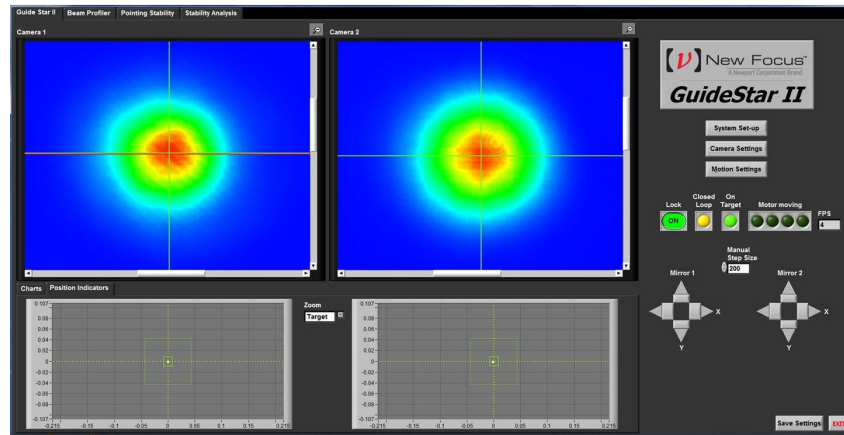

The GuideStar II provides high-reliability, high-precision compensation of laser pointing and position drift. Two independent New Focus™ Picomotor™ actuated motorized mirror mounts provide both manual and active 4-axis control with excellent passive stability. Two miniature position-sensing cameras provide continuous tracking of both laser beam positions and laser beam profiles. The position data is fed back to the mirror motion using our patented control algorithm (US Patent # 7,528,364 Optical Beam Steering and Sampling Apparatus and Method, 2009), the only technique that completely corrects the laser beam alignment in both x and y and near and farfield. The system is anchored by the small GuideStar™ II Controller and controlled through your own computer with a host of user-friendly and convenient features. Full beam profiles and position and shape data are available live or can be tracked, stored and analyzed. An easy Set-up Menu guides new users through the install and simple settings menus allow complete control of a wide range of camera and beam stabilization parameters including >100:1 dynamic camera exposure time, adjustment to optimize profile levels, and complete control of beam position target sizes and signal time averaging.

Designed for accuracy, reliability, and ease-of-use, the GuideStar™ II System is the answer to laser beam drift correction for the most demanding laser applications.

GuideStar System Specifications

GuideStar II System Specifications*	
Laser	
Laser Wavelength	350 - 1200 nm
Laser Repetition Rate	>500 Hz** to CW
Laser Beam Size	<10 mm diameter
Detected Power Required	<1mW
Position	
Beam Pointing Adjustment Range	+/-3 degrees, +/-50 mrad
Adjustable Target Sizes, Positions and Loop Gains	Yes
Minimum Pointing Step Size	<1 μrad
Pointing Stabilization	<10 μrad
Time	
Response Time	<10 seconds
Adjustable Time Averaging	Yes
Refresh rate for beam profile and display	>3 Hz

*Specifications are subject to change

**Trigger kit available for <500 Hz (8783-T)

GuideStar II System Components

GuideStar II Controller Model 8783

- Executable GUI installer provided for user computer
- USB connections to cameras and computer
- RJ-22 connections to Picomotor mirror mounts
- W x H x D: 140 x 80 x 200 mm
- 12 VDC via 100-220 VAC power adapter provided

GuideStar II Camera Sensor Model 8784

- 1 Megapixel CMOS, USB 2.0 interface
- Image Size: >10 mm diameter
- Beam Position Resolution: <1 μm
- Computer Controlled Exposure Range: 20 dB
- Manually Controlled Exposure Range: 50 dB
- W x H x D: 50 x 50 x 75 mm

Picomotor Mirror Mounts Model 8807*

*Alternate Model #s: 8816, 8821, 8852, 8885, 8886, 8887

System Requirements

- Full HD Display: 1920 x 1080
- 64 and 32 Bit Windows 7



GuideStar II Controller



GuideStar II Camera Sensor



8807* Picomotor Center Mount

Agilis™

The driving force behind Agilis

Agilis series motorized positioners are driven by the patented Agilis piezo direct motor. Agilis motors are built using a piezo ceramic embedded in an engineered spring blade with a special geometry. The motor is controlled by sending a calibrated asymmetric electrical pulse to the piezo ceramic to drive the motor in both positive and negative directions. Agilis piezo motors are directly coupled to the moving carriages with no intermediate screw or gear, providing motion free of errors typically associated with intervening mechanisms, such as backlash or hysteresis. Precision motion is achieved by proprietary ball bearings. The robust design of the piezo motor provides reliable performance and uninterrupted use.



Step Size vs Actual Motion

One of the most frequently asked questions about the Agilis family of products is:

“What is the relation between the step size and the actual motion of the Agilis device?”

In order to be able to answer to this question, we need to first understand that the step size of an Agilis device and its step amplitude are two different things. The step size of Agilis products is not repeatable. It varies from mount to mount and it differs between forward and backward motion. It somehow reminds us of human steps, which varies between tall and short people, tired and fresh people, athletic and non-athletic people, the load that is being carried during the motion, etc. Although the step size is adjustable, we cannot forecast the relation between step amplitude and step size for an individual mount. So our customers will need to measure the step size for a defined step amplitude on their own.

CONEX-Agilis absolute positioning and innovative encoder technology

Innovative miniature encoder technologies incorporated in CONEX-Agilis positioners, offer highly integrated position measuring systems without compromising compact construction. CONEX-Agilis rotary and linear stages are built with integrated direct read linear encoders, and CONEX-Agilis optical mounts, include integrated strain gauges for absolute positioning capability. With CONEX-Agilis optical mounts, returning to saved positions is possible, even after power cycling.

CONEX-Agilis Closed-Loop positioners are ideal for systems integration, with compact integrated controllers, position measurement capability, high position repeatability, consistent incremental motion steps and remote operation with a complete commands set. The CONEX-Agilis series offers an ideal solution for OEM and systems integration applications.

Included with CONEX-Agilis products, the CONEX-AGP controller is a very compact and inexpensive single axis motion controller with the same driver as the proven Agilis AG-UC2 2-axis, driver. The controller comes with the familiar CONEX GUI, simple and intuitive to use and conveniently accessible via USB, which also supplies power to the controller. The CONEX-AGP Closed-Loop algorithm is a simplified version of the typical DC servo loop algorithm. For stability in-position, the user can adjust the deadband parameter that stops dithering when the stage is within a set position tolerance.



Selection Guide

Description		Travel Range	Minimum Incremental Motion	Model #	Page
Optical Mounts					
	Motorized Optical Mounts	+/-2°	1-2 μrad	AG-MxN	Pg. 28
	Optical Mounts w/ Limit Switches	+/-2°	1-2 μrad	AG-MxL	Pg. 28
	Motorized Vacuum Compatible Optical Mounts	+/-2°	1-2 μrad	AG-MxV6	Pg. 28
	Closed-Loop Motorized Optical Mount	+/-0.75°	0.001°	CONEX-AG-M100D	Pg. 28
Stages					
	Motorized Rotary Stage	360°	0.0002°	AG-PR-100	Pg. 30
	Vacuum Compatible Rotation Stage	360°	5 μrad (1 arc-sec)	AG-PR100V6	Pg. 30
	Closed-Loop Motorized Rotary Stage	340°	0.001°	CONEX-AG-PR-100P	Pg. 31
	Closed-Loop Motorized Goniometric Cradles	+/-5.5°-+/-7.5°	0.00025°-0.00032°	CONEX-AG-GON-xP	Pg. 32
	Motorized Translation Stages	12-27 mm	0.05-0.1 μm	AG-LS25x	Pg. 33
	Motorized Vacuum Compatible Translation Stages	12-27 mm	0.05-0.1 μm	AG-LS25xV6	Pg. 34
	Closed-Loop Motorized Translation Stage	27 mm	0.2 μm	CONEX-AG-LS-25-27P	Pg. 34
Controllers and Drivers					
	Two-Axis Controller	-NA-	-NA-	AG-UC2	Pg. 35
	Two-Axis OEM Controller	-NA-	-NA-	AG-UC2-OEM	Pg. 35
	Eight-Axis Controller	-NA-	-NA-	AG-UC8	Pg. 36
	Eight-Axis OEM Controller	-NA-	-NA-	AG-UC8PC	Pg. 36

Agilis™ Motorized Mirror Mounts



Models (Left to Right): AG-M050N and AG-M100N

- Outstanding adjustment sensitivity
- Convenient remote operation
- Ultra-compact
- Set-and-forget long-term stability
- CONEX-Agilis with integrated strain gauge and controller
- Vacuum compatible versions

Agilis optical mounts feature Newport's proven, proprietary, non-resonant piezo motors. These highly integrated motors are directly coupled to the moving optics holder for robust and predictable performance. When idle, the motor spring force locks the mirror in place. Agilis mounts also have a fast adjustment speed and are free of issues associated with backlash or hysteresis. In contrast to ultrasonic motors, the Agilis non-resonant motors makes small adjustments more predictable. With 50 nm minimum incremental motion capability on each motor, Agilis mounts are ideal for sensitive alignment and optical adjustments.

For repeatable absolute positioning, the Agilis Motorized Mirror Mounts feature precision electrical limit switches. These switches act not only as safety devices, but allow repeatable absolute positioning without the need for expensive encoder feedback. This is accomplished by measuring the average step size from the left to the right travel limits and vice versa. Under constant conditions, the step size is fairly repeatable.

Model	AG-M050N	AG-M100N	AG-M050L	AG-M100L
Optic Diameter [in (mm)]	0.5 (12.7)	1.0 (25.4)	0.5 (12.7)	1.0 (25.4)
Angular Range (°)	±1.8	±2	±1.8	±2
Limit Switches	NA	NA	Proprietary electrical switches	Proprietary electrical switches
Adjustment Sensitivity (μrad)	2	1	2	1
Absolute Position Accuracy(°)	NA	NA	0.05 ⁽¹⁾	0.05 ⁽¹⁾
Maximum Speed (°/s)	0.75	0.5	0.75	0.5
Thermal Tilt (μrad/°C)	7	4	7	4
Weight (g)	25	85	25	85
Operating Temperature (°C)	+10 to +35	+10 to +35	+10 to +35	+10 to +35
Storage Temperature (°C)	-10 to +40 (in original packaging)	-10 to +40 (in original packaging)	-10 to +40 (in original packaging)	-10 to +40 (in original packaging)

Vacuum Model	AG-M050NV6	AG-M100NV6	AG-M050LV6	AG-M100LV6
Vacuum Compatibility	10 ⁻⁶ Torr	10 ⁻⁶ Torr	10 ⁻⁶ Torr	10 ⁻⁶ Torr

⁽¹⁾ Maximum position deviation between before an MA command (measure absolute current position) and after a PA command (move to absolute position).

Model AG-M050N

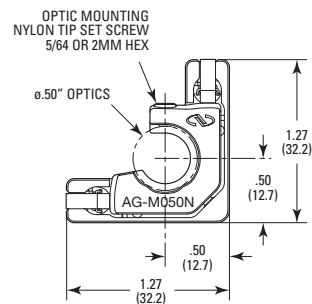
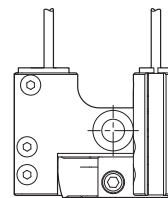

Model AG-M100N

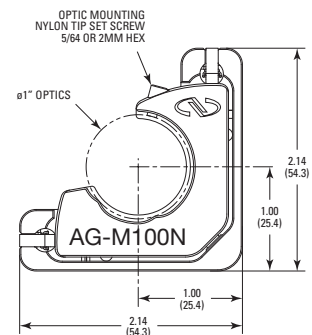
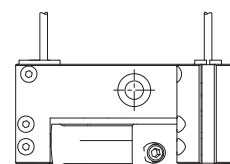

CONEX-Agilis™ Motorized Mirror Mount



Model CONEX-AG-M100D

- Closed-Loop
- Compact size
- Repeatable positioning
- Set-and-forget long-term stability

The CONEX-Agilis mirror mount has been designed with an integrated strain gauge to provide absolute positioning performance. Delivered with a compact, preconfigured CONEX controller, the CONEX-AG-M100D delivers repeatable positioning and is ideal for applications that require a return to a saved position. The CONEX-AG-M100D can also be power cycled without a loss to position feedback. This means that the position of the mount can be used as a diagnostic tool for alignment, while never requiring a reset of position. The integrated controller, also provides a full command set and only requires USB for power. CONEX-Agilis motorized mirror mounts are ideal for systems integration and remote adjustment of optics.

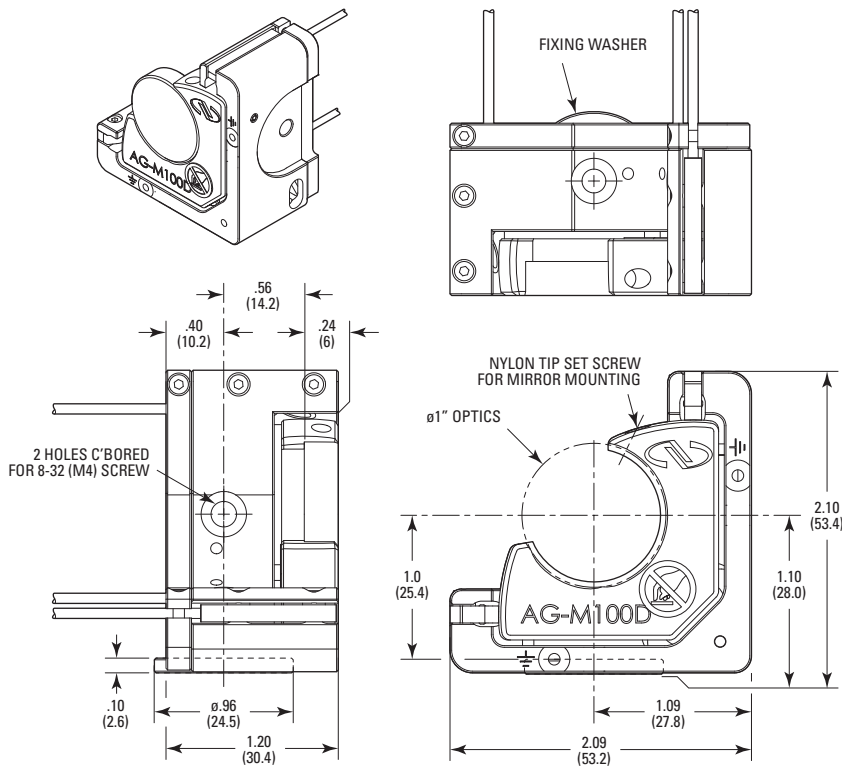

Model	CONEX-AG-M100D
Optic Diameter [in. (mm)]	1.0 (25.4)
Dual Axis Travel Range (°)	±0.75
Closed Loop MIM (°)	0.001
Repeatability (°)	0.01
Maximum Speed (°/s)	0.4
Temperature Stability (μrad/°C)	5

Agilis™ Rotation Stage



Model AG-PR100

- Ultra-high adjustment sensitivity
- Convenient remote operation
- Ultra-compact — ideal for systems integration
- Set-and-forget long-term stability
- Available with direct read encoder and CONEX controller

The Agilis Series of high precision miniature rotation stages feature Newport's Agilis piezo step direct motor. Agilis stages provide the benefits of ultra-high adjustment sensitivity and convenient remote operation at a price and size comparable to that of a high quality manual stage.

The ultra-compact and light weight AG-PR100 rotation stage features a 1 in aperture with retaining ring and is ideal for continuous rotation of waveplates and polarizers. With an optional top plate accessory (AG-PR100-TP), the stage can be used for small sampling positioning or other optics applications. The AG-PR100 is an ideal, cost-effective solution to making fine rotational adjustments of optical components and small samples. The AG-PR100 can be used with compact AG-UC2 and AG-UC8 controllers which can also drive additional positioners.

Model AG-PR100

MODEL SHOWN: AG-PR100
DIMENSIONS IN INCHES (AND MILLIMETERS)

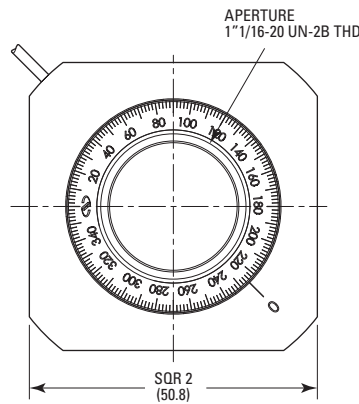
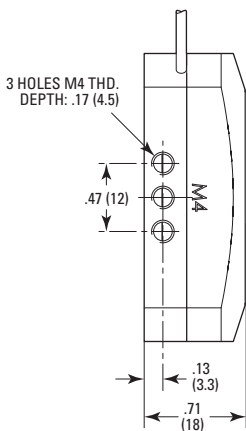
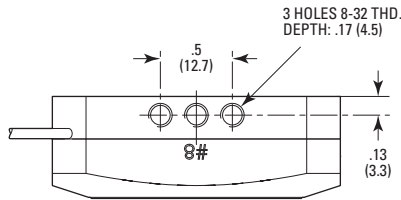

Model	AG-PR100
Travel Range (°)	360, continuous
Minimum Incremental Motion (μrad)(arc-sec)	5 (1)
Maximum Speed (°/s)	2
Weight (g)	135
Cable	1.2 m length, 4-wire mini-DIN connector Can extend cable length using AG-MD4-1.2 extension cable
Operating Temperature (°C)	+10 to +35
Storage Temperature (°C)	-10 to +40 (in original packaging)

Vacuum Model	AG-PR100V6
Vacuum Compatibility	10 ⁻⁶ Torr

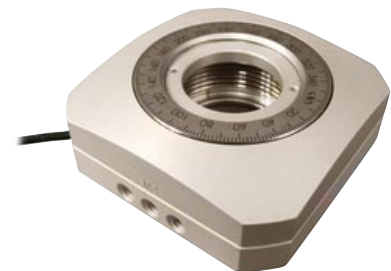

Model AG-PR100V6

CONEX-Agilis™ Rotation Stage



Model CONEX-AG-PR100P

- Highly repeatable angular motion
- High sensitivity (MIM)
- Compact size
- Integrated and easy to set up

The CONEX-AG-PR100P is a piezo motor rotary stage integrated with a Closed-Loop piezo motor controller/driver. Initially targeted for repeatable positioning of polarizing optics, it can also be used as a miniature rotation stage for precision positioning of other optics or lightweight samples.

The rotary stage of the CONEX-AG-PR100P is based on the Agilis AG-PR100 rotary stage, but features an innovative miniature direct read encoder. The footprint is maintained while delivering 0.002° uni-directional repeatability expected from direct read encoder technology. The rotary stage is very compact, but is capable of 340° travel and 0.001° MIM.

For OEM applications, an optional retainer to secure the USB and power cables is available. In addition, RS232 and RS485 communication are available at the board level.

Model CONEX-AG-PR100P

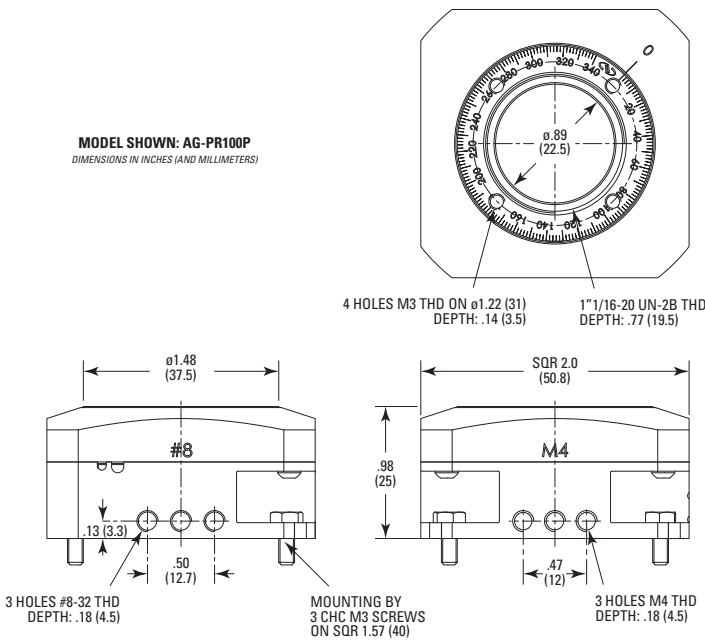

Model AG-PR100-TP

Use the AG-PR100-TP top plate to mount a goniometer or linear stage.



MODEL SHOWN: AG-PR100-TP
DIMENSIONS IN INCHES (AND MILLIMETERS)

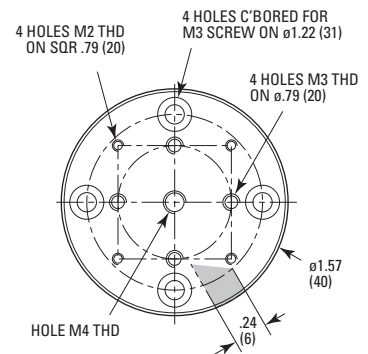

Model	CONEX-AG-PR100P
Travel Range (°)	340
Minimum Incremental Motion (°)	0.001
Uni-directional Repeatability Typical (°)	0.002
Bi-directional Repeatability, Typical (°)	0.003
On-Axis Accuracy, Typical (°)	0.08
Origin Repeatability (°)	0.002
Maximum Speed (°/s)	1.5
Wobble, Typical (μ rad)	100
Transversal Stiffness (k_{α}) (μ rad/Nm)	200
Maximum Torque (Mz) (Nm)	0.02
Normal Load Capacity (N)	2

CONEX-Agilis™ Goniometers



Model CONEX-AG-GON-LP

- Closed-Loop
- Compact footprint and light weight
- Highly repeatable angular motion with a direct read encoder

The CONEX-AG-GON goniometer stages are built on the same innovative Agilis piezo motor technology. These open frame stages provide easy access to the tip/tilt platform and can be stacked for multi-axis rotations. With innovative encoders and integrated controllers, Agilis Goniometers provide a rotational motion solution to compliment conventional rotation stages.

Model	CONEX-AG-GON-UP	CONEX-AG-GON-LP
Travel Range (°)	±7.5	±5.5
Minimum Incremental Motion (°)	0.00032	0.00025
Uni-directional Repeatability Typical (°)	0.00064	0.0005
Origin Repeatability (°)	0.00064	0.0005
Maximum Speed (°/s)	0.45	0.33
Normal Load Capacity (Cz) (N)	3.5	3.5

Model CONEX-AG-GON-LP

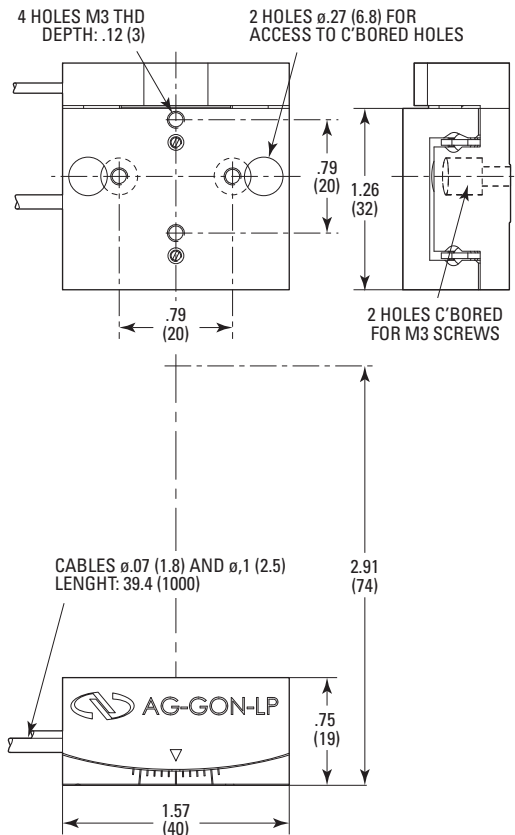

Model CONEX-AG-GON-UP

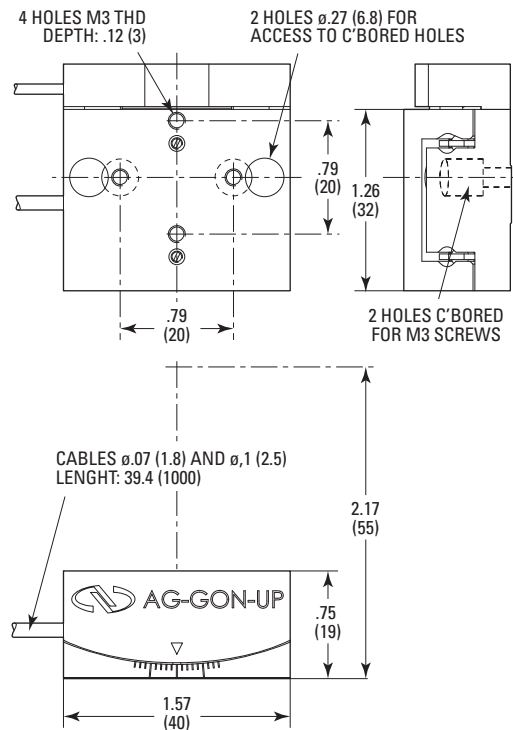

Use the AG-PR100-TP top plate to mount a goniometer or linear stage.

Agilis™ Linear Stages



Model AG-LS25

- Innovative Agilis proprietary piezo technology
- 12 & 27 mm travel and 50 nm Minimum Incremental Motion
- Set-and-forget long term stability
- Available with direct read encoder and CONEX controller

The AG-LS25 and AG-LS25-27 are high precision miniature linear stages featuring Newport's proprietary Agilis piezo motor. With ultra-high adjustment sensitivity, convenient programmable operation, and compact design, Agilis stages provide outstanding motion performance at the cost of a high-quality manual stage. Available with integrated encoder, the CONEX-AG-LS25-27P is well-suited for applications where repeatability is critical. For vacuum applications, see V6 versions of Agilis.

Agilis Linear Stages are available in 12 and 27 mm travel ranges. Precision motion is achieved by calibrated, pre-stressed linear ball bearings. The thermally matched stainless steel design and precision manufactured bearing surfaces provide ripple-free, low friction linear travel and angular deviations better than 100 μ rad in any axis. The Agilis piezo motor is also directly coupled to the moving carriage with no intermediate screw or gear avoiding problems with coupling in drivetrain. When idle, the holding force of the motor locks the position. In contrast to ultrasonic motors, the Agilis non-resonant motor makes small incremental adjustments more predictable with 50 nm incremental motion capability, ideal for ultra-sensitive alignments and adjustments.

Model AG-LS25

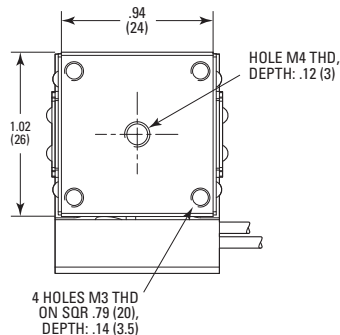
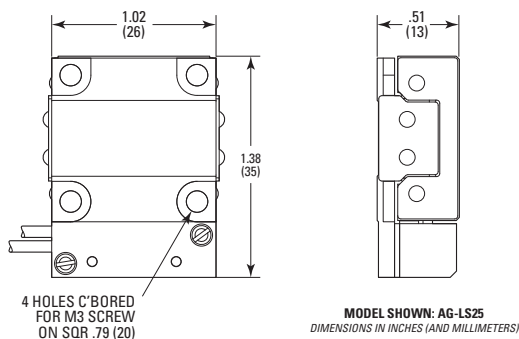

Model AG-LS25-27

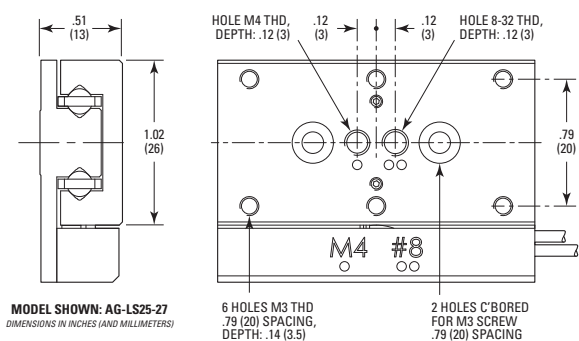
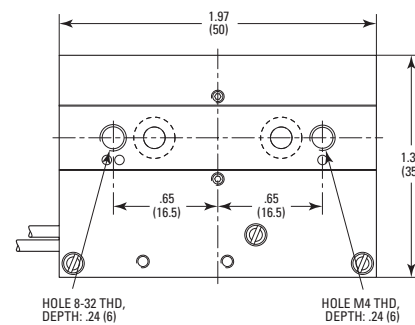

Model	AG-LS25	AG-LS25-27
Travel Range (mm)	12	27
Minimum Incremental Motion, Linear (μm) ¹	0.05	0.1
Normal Load Capacity (Cz) (N)	3	2.5
Axial Load Capacity (+Cx) (N) ³	2	1.5
Weight (g)	70	125
Absolute Positioning Accuracy (μm) ²	100	
Maximum Speed (mm/s)	0.5 with no axial load, >0.2 with 1.7 N axial load	
Holding Force (N)	4 N	
Material	Stainless Steel	
Cable	1.2 m length, 4-wire mini-DIN connector Can extend cable length using AG-MD4-1.2 extension cable	
Life Time	> 1000 m (> 500,000 cycles of ± 1 mm motion)	
Operating Temperature ($^{\circ}\text{C}$)	+10 to +35	
Storage Temperature ($^{\circ}\text{C}$)	-10 to +40 (in original packaging)	

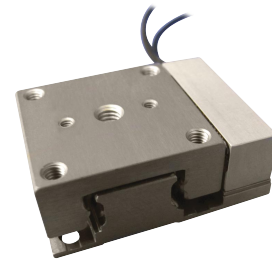

Model AG-LS25V6



Model AG-LS25-27V6

Vacuum Model	AG-LS25V6	AG-LS25-27V6
Vacuum Compatibility	10^{-6} Torr	10^{-6} Torr

¹ The step size for forward and backward direction is adjustable. With default settings, the step size for the forward direction varies from the step size for the backward direction and may be larger than 50 nm. Individual steps are not 100% repeatable.

² The AG-LS25 and AG-LS25-27 stages determine the average step size by counting the number of steps between the limits. The execution of an absolute positioning may take up to 80 s on these stages.

³ When used vertically, the axial load capacity is 0.4N.

CONEX-Agilis™ Linear Stage



- Closed-Loop positioning performance at an affordable price
- Integrated single-axis control for Agilis piezo motor products
- Ultra-compact controller and stage, great for tight spaces
- Repeatable, sub-micron motion
- Fast USB communication

Model	CONEX-AG-LS25-27P
Travel Range (mm)	27
Minimum Incremental Motion, Linear (μm) ¹	0.2
Absolute Positioning Accuracy (μm) ²	15
Maximum Speed (mm/s)	0.4
Normal Load Capacity (Cz) (N)	3.5
Holding Force (N)	4
Axial Load Capacity (+Cx) (N) ³	1.5
Material	Stainless Steel
Weight (g)	125
Cable	1.2 m length, Integrated
Life Time	> 1000 m (> 500,000 cycles of ± 1 mm motion)
Operating Temperature ($^{\circ}\text{C}$)	+10 to +35
Storage Temperature ($^{\circ}\text{C}$)	-10 to +40 (in original packaging)



The CONEX-AG-LS25-27P linear stage integrates an innovative miniature encoder for position feedback and closed loop operation, offering exceptional repeatability.

¹ The step size for forward and backward direction is adjustable. With default settings, the step size for the forward direction varies from the step size for the backward direction and may be larger than 50 nm. Individual steps are not 100% repeatable.

² For absolute positioning, the CONEX-AG-LS25-27P uses an integrated encoder for closed-loop operation. The execution of an absolute positioning may take up to 80 s on these stages.

³ When used vertically, the axial load capacity is 1 N.

Agilis™ Controllers and Drivers



- Compatible with all Agilis piezo motor-driven products
- Available in: 2-channel hand-held AG-UC2 or the 8-channel AG-UC8, both with USB interface
- Available in the 8-channel AG-UC8PC, with USB, RS-232 and RS-485 interfaces
- ASCII commands, Windows DLL's and LabVIEW VI's included
- Optional USB power supply

Agilis piezo motor controllers are available in 2 or 8 channel versions. The 2-channel, hand-held, AG-UC2, can be driven through a USB port or from the independent USB-CH power supply. Both Agilis AG-UC8 and AG-UC8PC controllers have the capability to drive up to 8 piezoelectric motors. They can be powered through the USB port directly from the computer and the AG-UC8PC version can also be powered from an external power supply. A software utility allows driving two selected motors (1&2, 3&4, etc) at a time and switching to another motor pair.

A set of ASCII-commands, Windows DLL and LabVIEW VI's for all functions are provided.

AG-UC2

The Agilis AG-UC2 controller provides convenient push button remote control and USB computer control for two Agilis axes.

For each axis, the AG-UC2 controller features two sets of push buttons, the top for step size settings and the bottom set for precise, low speed adjustments and fast coarse motion.

Power is supplied through the USB port and if not available, the USB-CH power supply can independently power the Agilis controller. USB hubs may also be used for power and communication, but must provide the required 5 V supply, e.g. must have an external power supply.

The GUI that comes with the controller, allows the user to remotely operate the controller through the computer. The GUI provides the ability to select another AG-UC2 controller and operate the connected Agilis stages.

AG-UC2-OEM

The AG-UC2-OEM Agilis Driver is designed to be integrated into OEM equipment by mounting directly onto your printed-circuit board. It can drive 2 axes at a time. If appropriately multiplexed it can be used switch between Agilis nanopositioners that have been embedded into your system. In a small compact platform, the OEM board provides convenient control adjustments of Agilis components that you can easily interface with it and build it into your device, instrument, or laboratory setup. The Model AG-UC2-OEM driver module requires an external power supply.

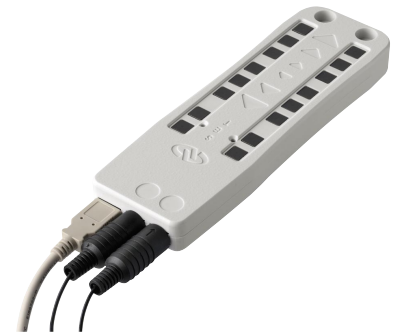

AG-UC2 Hand-held 2-axes controller

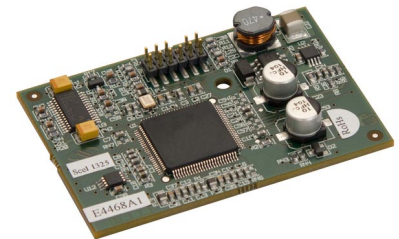

AG-UC2-OEM PCB-Mountable 2-Axis Agilis Driver

AG-UC8



AG-UC8 Compact 8-axis controller

The Agilis AG-UC8 controller provides USB computer control of up to 8 Agilis axes*.

Power is supplied through the same USB port used for communication. USB hubs may also be used for powering and communication, but must provide the required 5 V supply, e.g. must use an external power supply.

A virtual software utility allows selecting any channel (1 to 4), that drives either of the two piezo motors (1&2 or 3&4, etc). Apart from selecting the active motor pairs, the AG-UC8 uses the same ASCII-commands, DLL and LabVIEW VI's as the AG-UC2. An LED indicates the current controller status. Two holes in the controller allow stacking of several controllers and attachment to optical tables.

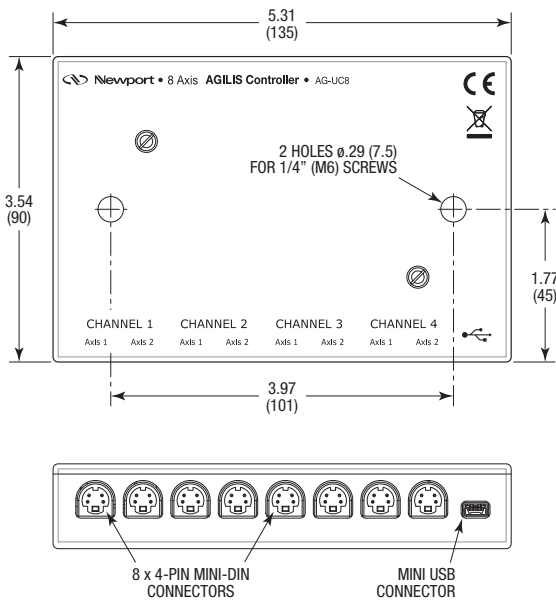

AG-UC8PC

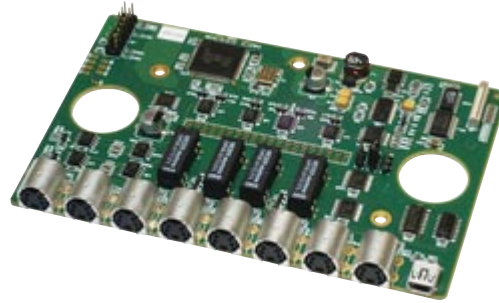

AG-UC8PC 8-axis PC Card controller

The Agilis AG-UC8PC is primarily intended for industrial customers and system integrators. It provides the same features and functions as the AG-UC8 controller, but comes as a PC-card without an enclosure nor cables for flexibility in assembly.

In addition to the mini-USB connector for USB communication, the AG-UC8PC provides an additional HE10 connector on the board for RS-232 and RS-485 communication. The active communication channel is set by jumpers.

A virtual software utility allows selecting any channel (1 to 4), that drives either of the two piezo motors (1&2 or 3&4, etc). A set of ASCII-commands, Windows DLL and LabViewVI's for all functions are provided and are fully compatible with the ones used in the AG-UC2 and AG-UC8. An LED indicates the current controller status.

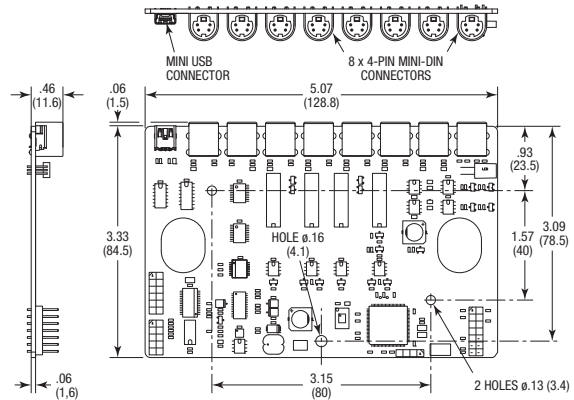

* Note: An Agilis optical mount is driven by 2 piezo motors whereas, an Agilis linear or rotation stage are driven by one piezo motor only.

Model	AG-UC2	AG-UC2-OEM	AG-UC8	AG-UC8PC
Description	Compact Piezo Motor Controller, 2 Axis, Hand-held	PCB-Mountable 2-Axis Agilis Driver	Compact Piezo Motor Controller, 8 Axis	8 Axis OEM Agilis Piezo Controller, USB/RS232/RS485
Number of axes	2	2	8	8
Interface	Push buttons and USB	Direct PCB	USB	USB, RS-232 and RS-485
Power input	Through USB interface	Through PCB Connection	Through USB interface	USB: Through USB RS-232 and RS-485: 5 V through HE10 connector
Size (mm)	177 x 57 x 19	55 x 40 x 15	135 x 90 x 25	130 x 85

NanoPZ



Model PZA12

- High reliability operation with 30 nm motion sensitivity over 12.5 mm travel
- Fast speed (> 0.2 mm/s) and high load capacity (50 N)
- Non-rotating tip
- No loss of position with removal of power; ideal for set-and-forget applications

The NanoPZ Ultra-High Resolution Actuator provides exceptional nanometer-scale remote control of manual-positioning stages and opto-mechanical components over large distances, in hard to reach spaces and in hazardous hands-off applications, like high-power laser experiments.

The NanoPZ's non-rotating tip prevents contact surface wear and allows for direct load attachments. Newport's exclusive design and innovative piezo motor ensures 30 nm incremental motion capability with no loss of position when power is removed. The NanoPZ incorporates the exclusive piezo micro stepping motor and with ergonomic controls, provides consistent results, superior reliability and unmatched ease-of-use. All this, plus >0.2 mm/s speed and 50 N load capacity.

The NanoPZ is compatible with an array of Newport products including ULTIMA® Series optical mounts, GON Series goniometers, and ULTRAlign™ Series of linear stages.

NanoPz Design Details

Model	PZA12
Base Material	Aluminum
Drive Mechanism	Direct-drive non-rotating lead screw, no gear
Feedback	Open loop, no encoder
Limit Switches	Fixed, jam-proof hard limits
Origin	None
Motor	Non-resonant piezo micro-stepping
Average Full-Step Size	Approx. 160 nm depending on load, speed and other parameters. 16 micro-steps per full-step. Step size is not repeatable.
Cable Length (m)	3
Weight [lb (kg)]	0.29 (0.13)

NanoPz Specifications

Model	PZA12
Travel Range [in. (mm)]	0.5 (12.5)
Minimum Incremental Motion, Linear (μm)	0.03
Repeatability/Accuracy	Varies depending on application and feedback method
Maximum Speed (mm/s)	0.2
Axial Load Capacity (+Cx) (N)	50

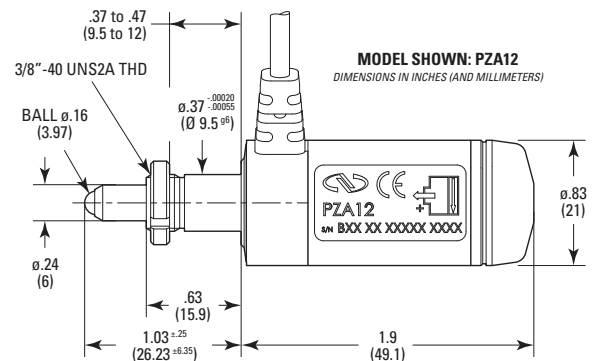

NanoPz Controllers and Accessories

Nano PZ Controller



PZC200 controller with PZA12 actuator.

The PZC200 controller provides convenient and ergonomic one hand speed control, and easy to use push button channel control for the PZC-SB switchbox. The PZC200 is equipped with a serial RS-485 computer link for computer control of up to 256 units in parallel. RS-485 is accessed by using the RS-485 to RS-232 converter NSC-CB-485-232-1 plugged into the PC's RS-232 port. For USB connectivity, use the optional USB-232 RS-232 to USB converter.



PZC-SB Switchbox

The PZC-SB allows control of up to 8 NanoPZ actuators from the same PZC200 controller. LEDs indicate which actuator is active, inactive, connected, or disabled. The two buttons on the PZC200 controller allow the selection of the active actuator. The PZC-SB is controllable via PC using the same RS-485/RS-232 interface as the PZC200.

Nano PZ Controller Specifications

Model	PZC200
Number of Controlled Axes	1 8 with PZC-SB switchbox
Operating Modes	1. Local (manual) control mode 2. Remote (computer) control mode
Controls, Local (manual) Mode	Rotate knob to adjust speed Select active switchbox channel Toggle between local and remote mode Set current position to zero
Controls, Remote (computer) Mode	ASCII commands, I/O via RS-485 port
Micro-stepping	1 micro-steps equals approx 10nm of motion depending on the load, speed and other parameters
Dimensions [in(mm)]	6 x 2 x 2 (150 x 50 x 50)
Weight [lb (kg)]	0.55 (0.25)

PZC-SB Specifications

Model	PZC-SB
Actuator Output Channels	8 (one channel active at a time)
Channel Status Indication	3 - color LED per axis
Dimensions (W x D x H) [in(mm)]	6 x 2 x 2 (150 x 50 x 50)

Ordering Information

Model	Description
PZC200	Hand-held controller for PZA12
PZC-SB	PZC200 Switchbox, Includes Power, Driver & Controller Cables
PZC200-KT	PZA12 Actuator Kit, PZC200 Cont. NSC-PS25 Power Supply, NSC-PSC3 Cable
NSC-PS25	Power Supply, Connect up to 4 Motors
NSC-PSC1	Power Supply Cable, 1 m, Branch to Connect Additional Motor
NSC-485-232-I	RS-485 to RS-232 Converter, 6-wire Cable

Typical Configurations

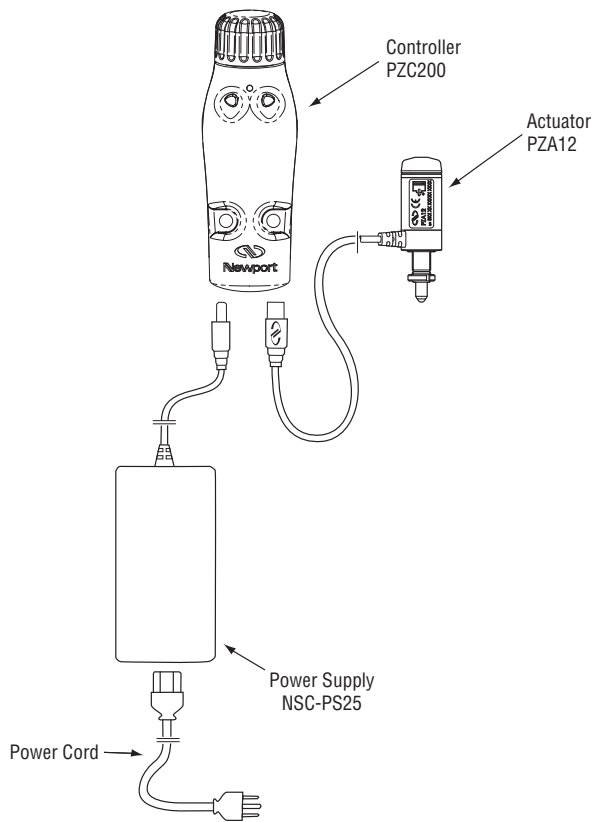

Connection diagram for one actuator and one controller with no computer interface.

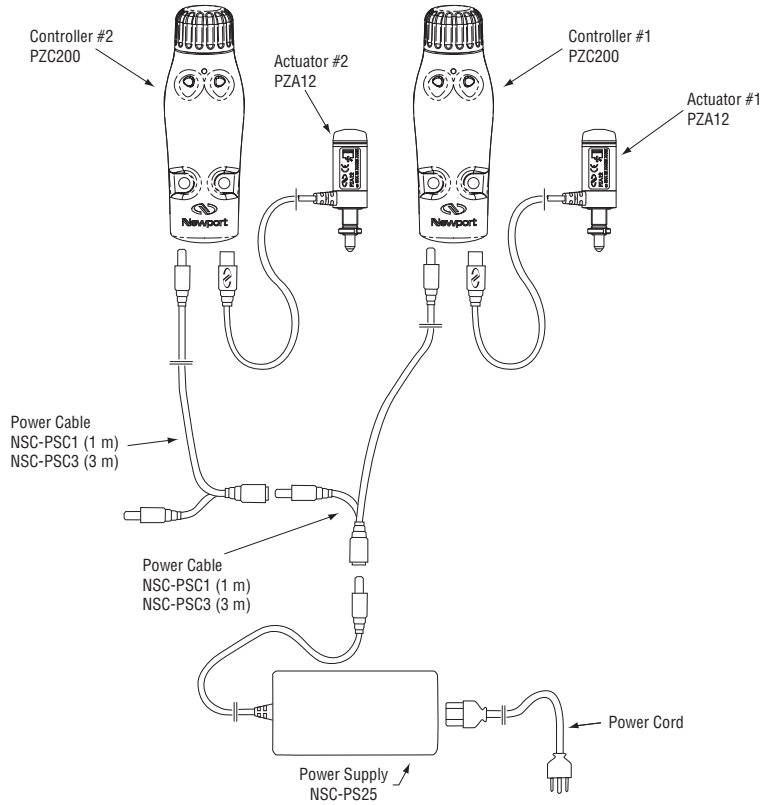

Connection diagram for two actuators and two controllers with one power supply and with no computer interface.

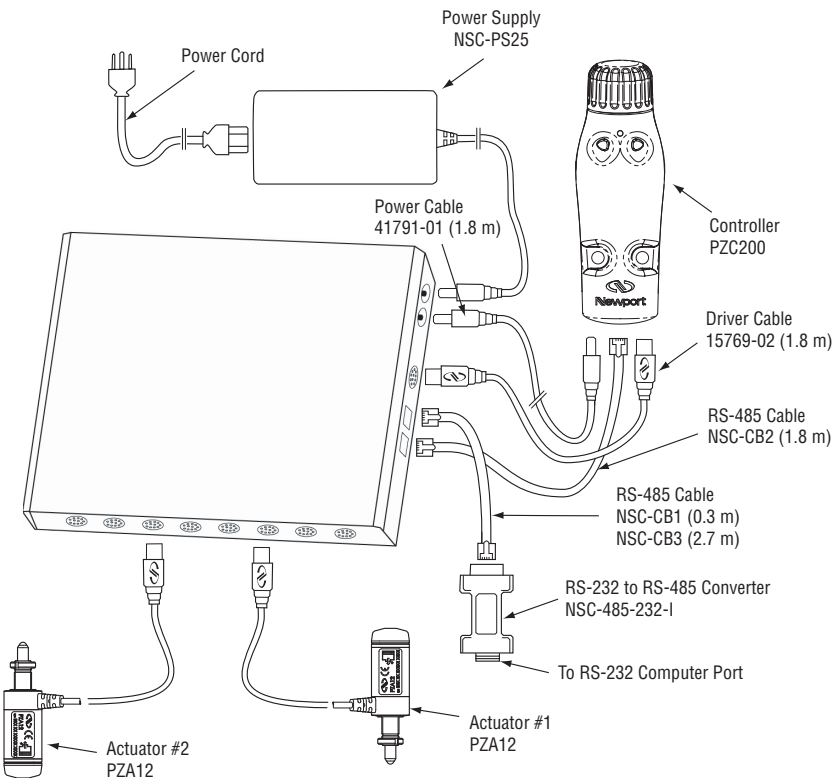

Connection diagram for several actuators and one controller with switchbox and with computer interface.



Model NSC-485-232-I



Model	Description
PZC200	Hand-held controller for PZA12
PZC-SB	PZC200 Switchbox, Includes Power, Driver & Controller Cables
PZC200-KT	PZA12 Actuator Kit, PZC200 Cont. NSC-PS25 Power Supply, NSC-PSC3 Cable
NSC-PS25	Power Supply, Connect up to 4 Motors
NSC-PSC1	Power Supply Cable, 1 m, Branch to Connect Additional Motor
NSC-485-232-I	RS-485 to RS-232 Converter, 6-wire Cable

Piezo Stack Nanopositioners

The NP Series is a family of compact, piezo-based nanopositioning stages providing nanometer resolution motion in one, two or three axes. NP Series stages feature highly reliable, multi-layer, low-voltage piezoelectric transducer (PZT) stacks for high-duty cycle operations. Ranging from linear stages, actuators, and micrometer adapters to ultrafast piezo steering mirror and objective nanofocusing stages, sophisticated, FEA-optimized, parallelogram solid state flexure guide systems ensure perfectly straight motion and up to 400 μm travel range in various nanopositioning applications. Due to the frictionless guide principle, NP Series stages are maintenance-free and are not subject to wear. Furthermore, the output motion sensitivity is not affected by mechanical friction.

One advantage of the NP series piezo-based stages is the rapid response and fast settling performance. This allows them to be used in dynamic processes such as high-frequency error compensation, tracking, fast stepping or continuous scanning.

All NP Series are available as Open-Loop (no position feedback) or Closed-Loop devices with integrated position feedback (strain-gauge, model numbers ending in -SG). In Open-Loop, the resolution is only limited by the noise of the control electronics, but repeatability and stability are compromised due to the hysteresis and creep of the piezoelectric ceramic material. The Closed-Loop systems feature high resolution strain-gauge position sensors for highly accurate and repeatable motion. The position feedback compensates also for actuator creep. For the highest position stability and most temperature insensitive performance, the sensors are built in a full Wheatstone bridge design. The closed-loop devices can be operated in either open or Closed-Loop control.

Series	Series	Description	Travel Range	Resolution	Page
Actuators					
	NPA	Piezo Translators	25-100 μm	0.05 - 0.2 nm	41
	NPA-V6	Vacuum Piezo Translators	25-100 μm	0.05 - 0.2 nm	41
	NPA-SG	Piezo Translators w/ Strain Gauge	20-80 μm	0.5 - 2.0 nm	41
	NPA-SGV6	Vacuum Piezo Translators w/ Strain Gauge	20-80 μm	0.5 - 2.0 nm	41
	NPM	Piezo Micrometer Adaptor	140 μm	0.1 nm	42
	NPM-SG	Piezo Micrometer Adaptor w/ Strain Gauge	90 μm	1 nm	42
Stages					
	NPX	Motorized Linear Stages	100-400 μm	0.2 - 0.8 nm	43
	NPX-V6	Vacuum Motorized Linear Stages	100 μm	0.2 nm	43
	NPX-SG	Motorized Linear Stages w/ Strain Gauge	80-320 μm	2 - 8 nm	44
	NPX-SGV6	Vacuum Stages w/ Strain Gauge	80-320 μm	2 - 8 nm	44
	PSM	Ultrafast Piezo Steering Mirror	16 μm	0.03 nm	45
	PSM-SG	Ultrafast PSM w/ Strain Gauge	12 μm	3 nm	45
	NPO	Objective Focusing Stages	140-250 μm	0.3 - 0.5 nm	46
	NPO-V6	Vacuum Objective Focusing Stages	250 μm	0.5 nm	46
	NPO-SG	Objective Focusing Stages w/ Strain Gauge	100-200 μm	3 - 5 nm	46
	NPO-SGV6	Vacuum Objective Focusing Stages w/ Strain Gauge	200 μm	5 nm	46
Controllers and Drivers					
	NPC3	3-Channel Open-Loop Controller	-	-	48
	NPC3SG	3-Channel Strain-Gauge Controller	-	-	48
	XPS-Q4	4-Axis Universal Controller/Driver	-	-	48

Note: Strain Gauge (SG) Models are Closed-Loop Control while non-SG models are Open-Loop Control

NPA Series



Models (Left to Right): NPA100, NPA50, NPA25

- Piezoelectric translators in a compact package
- Piezoelectric travel range up to 100 μm
- Sub-nanometer positioning resolution
- Integrates easily into custom motion systems
- Optional strain-gauge position feedback

The NPA Series Piezo Translators are ideally suited for integration into custom motion devices. They provide nanometer resolution, up to 100 μm travel range, and micro-second response time in a very compact housing.

NPA translators are equipped with a highly reliable, multi-layer, low-voltage, piezoelectric transducer (PZT) stack protected by a cylindrical stainless steel housing. The high internal mechanical preload simplifies handling and allows for high load, dynamic applications.

NPA series piezoelectric translators can generate large forces up to 1000 N which makes them particularly useful for machine tools, active vibration isolation, or adaptive mechanics. Their small size and high resonant frequency are suitable for scanning microscopy, laser tuning and beam steering, patch clamping or micro lithography applications.

NPA series piezoelectric actuators are available as open-loop (no position feedback) or closed-loop devices with integrated position feedback. In open-loop, the resolution is only limited by the noise of the control electronics, but repeatability and stability are compromised due to the hysteresis and creep of the piezo ceramic material. The closed-loop systems (model number ending in SG) feature high resolution strain-gauge position sensors for highly accurate and repeatable motion. Also, the position feedback compensates for actuator creep. The assembly is done as a full Wheatstone bridge and is temperature insensitive. The closed-loop devices can be used in either open or closed-loop control.

Fastening is accomplished by M3-threads at the top and the base of the translator. Like all piezoelectric devices, moment loads and side forces should be avoided. Spanner flats are provided and should be used when securing screws.

Model	NPA25 (-D)	NPA50 (-D)	NPA100 (-D)
Open loop travel range ($\pm 10\%$), (μm) ¹	25	50	100
Open loop resolution (nm)	0.05	0.1	0.2
Capacitance ($\pm 20\%$) (μF)	2.5	5.4	9.0
Resonant frequency, unloaded (Hz)	12,000	8,000	3,000
Axial stiffness (N/ μm)	40	20	10
Push/Pull load capacity (N)	1000/150	1000/150	1000/150

Vacuum Model	NPA25V6	NPA50V6	NPA100V6
Vacuum Compatibility	10 ⁻⁸ Torr	10 ⁻⁶ Torr	10 ⁻⁸ Torr

¹ Typical value measured with NPC3 (-20 V to +130 VDC range).

Model	NPA25SG (-D)	NPA50SG (-D)	NPA100SG (-D)
Closed loop travel range (μm) ^{1,2}	20	40	80
Closed loop resolution (nm) ²	0.5	1.0	2.0
Typ. Repeatability (nm) ²	16	20	28
Capacitance ($\pm 20\%$) (μF)	2.5	5.4	9.0
Resonant frequency, unloaded (Hz)	12,000	8,000	3,000
Axial stiffness (N/ μm)	40	20	10
Push/Pull load capacity (N) ³	1000/150	1000/150	1000/150

Vacuum Model	NPA25SGV6	NPA50SGV6	NPA100SGV6
Vacuum Compatibility (torr)	10 ⁻⁸ Torr	10 ⁻⁶ Torr	10 ⁻⁶ Torr

¹ Typical value measured with NPC3SG, (-20 V to +130 VDC range).

² Applies to devices ending with SG in closed-loop control only.

³ Maximum load that can be applied in the direction of motion. For multi-axis systems, read as X/Y/Z.

NPM Series



- Nanometer positioning sensitivity for manual products
- Piezoelectric travel range of 140 μm
- 100 N axial load capacity
- Compatible with all manual stages with 3/8" mounting bores

NPM140SG shown with AJS100-2. Order actuators separately.

The NPM140 Piezoelectric micrometer adapter provides nanometer positioning capability for manual products. This adapter mounts to the actuator seat on the stage and is mechanically compatible with all Newport stages, mounts and actuators with $\text{\O} 0.375"$ ($\text{\O} 9.5\text{mm}$) mounting flange*.

Pre-adjustment is done with the manual screw in the same way as without the adapter. Final, fine adjustment relative to the manually set position is accomplished by controlling the piezo voltage of the NPM140. An extraordinary long piezo travel range of 140 μm is provided by a sophisticated wire EDM flexure system. The flexure serves also as a linear guide for the actuator tip. Resolution of the piezoelectric motion is in the sub-nanometer range.

The NPM140 is available as open-loop (means no position feedback) or closed-loop device with integrated position feedback (NPM140SG). In open-loop, the resolution is only limited by the noise of the control electronics, but repeatability and stability are compromised due to the hysteresis and creep of the piezo ceramic material. The NPM140SG features a high resolution strain-gauge position sensor for highly accurate and repeatable motion. Also, the position feedback compensates for actuator creep. For highest position stability and highest temperature-insensitive performance, the sensor is assembled in a full Wheatstone bridge design. The NPM140SG can be operated in open or closed-loop control.

*Note: The adapter holds the manual screw 22 mm back from its normal position. Hence, in order to use the total travel range provided by the mechanic, actuators with 22 mm longer travel than recommended should be used with all devices.

Model	NPM140 (-D)
Open loop travel range ($\pm 10\%$), (μm) ¹	140
Open loop resolution (nm) ²	0.1
Capacitance ($\pm 20\%$) (μF)	1.7
Resonant frequency, without drive (Hz)	670
Axial stiffness (N/ μm)	0.4
Max. axial load (N)	100
Weight (g)	125

¹ Typical value measured with NPC3 (-20 V to +130 VDC range).

² Equal to rms noise value measured with NPC3 controller.

Model	NPM140SG (-D)
Closed loop travel range (μm) ^{1,2}	90
Closed loop resolution (nm) ²	1
Typ. Repeatability (nm) ²	35
Capacitance ($\pm 20\%$) (μF)	1.7
Resonant frequency, without drive (Hz)	670
Axial stiffness (N/ μm)	0.4
Max. axial load (N) ³	100
Weight (g)	125

¹ Typical value measured with NPC3SG, (-20 V to +130 VDC range).

² Applies to devices ending with SG in closed-loop control only.

³ Maximum load that can be applied in the direction of motion. For multi-axis systems, read as X/Y/Z.

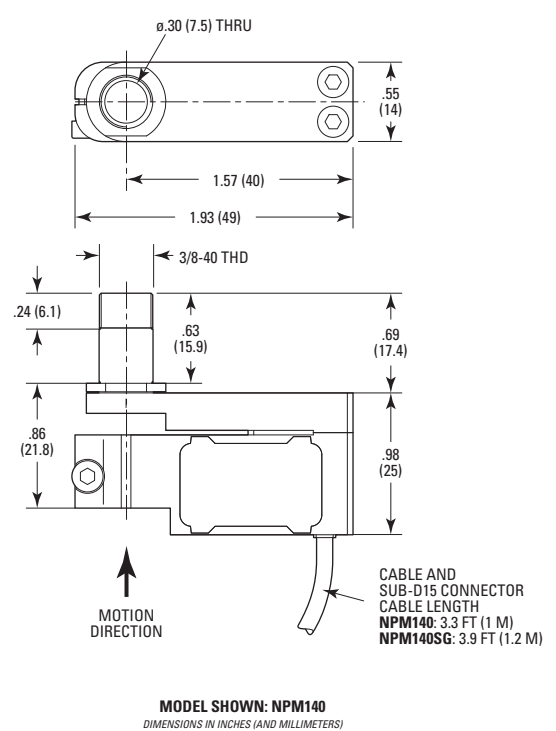

NPX Series



NPX Series

- Sub-nanometer piezoelectric positioning resolution
- Motion in X, XY, or XYZ
- Piezoelectric travel range of up to 400 μm
- Precision parallelogram design for accurate linear displacements
- High resonant frequency for high dynamic applications

The NPX Series is a family of compact, long travel piezo-based linear stages providing nanometer resolution motion in one, two, or three axes. These versatile stages are ideally suited for nanopositioning of small components such as mirrors, fibers, laser diodes, micro-optics, sensors, or cellular samples. Applications include optical delay lines, path length changes of interferometers, laser lithography, scanning microscopy, and patch-clamping, among others.

NPX stages feature highly reliable, multi-layer, low-voltage piezoelectric transducer (PZT) stacks for high-duty cycle operations. A sophisticated, FEA-optimized, parallelogram solid state flexure guide system ensures perfect parallel motion and up to 400 μm travel range. Due to the frictionless guide principle, NPX stages are maintenance-free and are not subject to wear. Furthermore, the output motion sensitivity is not affected by mechanical friction.

NPX linear stages are available as X, XY, and XYZ motion systems. The multi-axis XY and XYZ devices utilize an advanced parallel motion principle, meaning all actuators act directly on the moving platform. Smaller form factor and lower inertia for faster motion can be achieved as opposed to other PZT systems with serial kinematics such as stacks of individual stages. In addition, the NPXY100 and NPXY200 models feature a large central aperture which makes them particularly suitable for microscopy applications.

All NPX linear stages are available as open-loop (no position feedback) or closed-loop devices with integrated position feedback. In open-loop, the resolution is only limited by the noise of the control electronics, but repeatability and stability are compromised due to the hysteresis and creep of the piezoelectric ceramic material.

Fastening is accomplished by a number of threads and alignment pin holes at the top and bottom plates. For mounting to optical tables or other components with the same hole grid, use adapter plate NPX-BP. Like with all piezo flexure devices, excessive moment loads and side forces acting between the top plate and the housing should be avoided during fastening. These external forces could damage the stage.

Model	NPX200 (-D)	NPX400 (-D)	NPXY100 (-D)	NPXY200 (-D)	NPXYZ100 (-D)
Axes	X	X	X,Y	X,Y	X,Y,Z
Travel per axis ($\pm 10\%$), (μm) ¹	200	400	100	200	100
Open loop resolution (nm) ²	0.4	0.8	0.2	0.4	0.2
Capacitance ($\pm 20\%$) (μF)	1.8	5.2	1.8	5.2	1.8
Resonant frequency, unloaded (Hz)	177	200	380/480	350/350	500/550/480
Resonant frequency, with 80 g load (Hz)	-	-	-	-	210/200/300
Resonant frequency, with 105 g load (Hz)	-	-	-	-	190/180/250
Resonant frequency, with 300 g load (Hz)	-	-	-	-	110/110/150
Axial stiffness (N/ μm)	0.08	0.16	1.1/0.95	0.65/0.6520	1/1/1
Max centered load (N)	10	10	75	100	30
Max axial load (N) ³	16	64	110/95	40/40	40/40/32
Weight (g)	180	180	175	350	165
Vacuum Model	NA	NA	NA	NA	NPXYZ100V6
Vacuum Compatibility	-	-	-	-	10 ⁻⁶ Torr

¹ Typical value measured with NPC3 (-20 V to +130 VDC range).

² Equal to rms noise value measured with NPC3 controller.

³ Maximum load that can be applied in the direction of motion. For multi-axis systems, read as X/Y/Z.

Model	NPX200SG (-D)	NPX400SG (-D)	NPXY100SG (-D)	NPXY200SG (-D)	NPXYZ100SG (-D)
Axes	X	X	X,Y	X,Y	X, Y, Z
Closed loop travel per axis (μm) ^{1,2}	160	320	80	160	80
Closed loop resolution (nm) ²	4	8	2	4	2
Typ. Repeatability (nm) ²	36	75	36	45	30
Capacitance (± 20%) (μF)	1.8	5.2	1.8	5.2	1.8
Resonant frequency, unloaded (Hz)	177	200	380/480	350/350	500/550/480
Resonant frequency, with 80 g load (Hz)	-	-	-	-	210/200/300
Resonant frequency, with 105 g load (Hz)	-	-	-	-	190/180/250
Resonant frequency, with 300 g load (Hz)	-	-	-	-	110/110/150
Axial stiffness (N/μm)	0.08	0.16	1.1/0.95	0.65/0.6520	1/1/1
Max centered load (N)	10	10	75	100	30
Max axial load (N) ³	16	64	110/95	40/40	40/40/32
Weight (g)	180	180	175	350	165

Vacuum Model	NPX200SGV6	NPX400SGV6	NPXY100SGV6	NA	NPXYZ100SGV6
Vacuum Compatibility	10 ⁻⁶ Torr	10 ⁻⁶ Torr	10 ⁻⁶ Torr	-	10 ⁻⁶ Torr

¹ Typical value measured with NPC3SG, (-20 V to +130 VDC range).

² Applies to devices ending with SG in closed-loop control only.

³ Maximum load that can be applied in the direction of motion. For multi-axis systems, read as X/Y/Z.

Vacuum NPX Series

Model NPXYZ100SG



Vacuum Compatible to 10⁻⁶ Torr

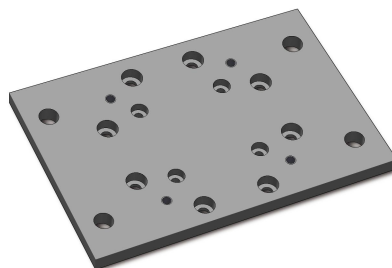

NPX-BP adapter plate

PSM Series



Model PSM2SG

- Ultra-fast, two-axis rotation and linear Z-motion for up to 50 mm diameter optics
- Piezoelectric travel range of 2 mrad or 16 μm
- Direct piezo design provide high-bandwidth control
- Ultra-compact

The PSM2 is a high-speed, tip, tilt, and Z motion piezoelectric stage for mirrors, gratings and other optics with sub-microradian resolution. Equipped with a direct piezoelectric actuation system, minus the lever arm transmission, the PSM2 is ideally suited for high bandwidth laser beam steering, switching and stabilization, beam scanning, image stabilization, and laser cavity tuning.

Fast and reliable motion is supplied by three, multi-layer, low-voltage piezo stacks (PZT) in a triangle configuration. The length of each piezo stack can be controlled individually, applying a voltage to one stack, results in a tip or tilt. Changing the length of all three stacks simultaneously, results in a linear Z-displacement.

For simple operation, the three piezo stacks of the PSM2 are arranged in a right triangle configuration. This results in orthogonal rotation without the need for coordinate transformations that is required in designs where the piezo stacks are placed at 120° intervals.

The parallel design of the PSM2 piezo stacks also has the advantage of being fully temperature compensated, i.e. changes in the environmental temperature do not affect the tilting angle. PSM2 units are also maintenance-free and are not subject to wear.

The PSM2 is available as an open-loop (no position feedback) or a Closed-Loop device with an integrated strain gauge position feedback. The Open-Loop version is ideal for applications where the position is controlled by an external sensor, e.g. a lateral effect diode, quad cell, photodiode, CCD camera, etc.

The PSM2 models are internally preloaded and can be mounted in any orientation. The PSM2 supports mirrors up to 50 mm diameter and can be glued directly to the top plate.

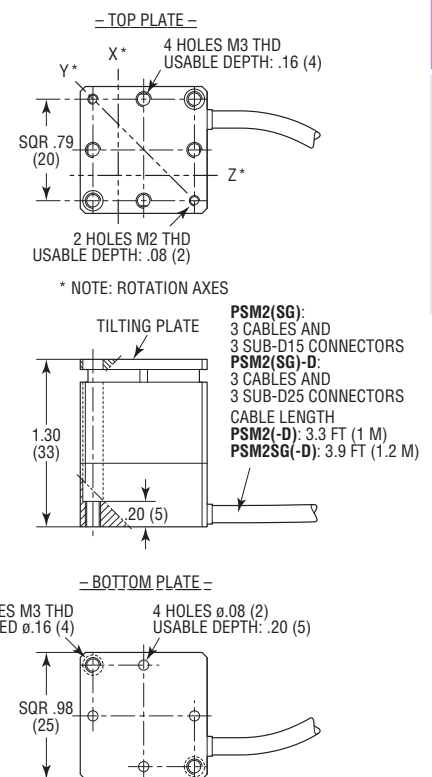

DIMENSIONS IN INCHES (AND MILLIMETERS)

Model	PSM2 ⁵	PSM2SG ⁵
Control System	Open-Loop	Closed-Loop
Active Axes	Θ_x, Θ_y, Z	Θ_x, Θ_y, Z
Angular Range, x, y ($\pm 10\%$) (mrad) ^{1,3}	2	1.6
Travel Range, Z ($\pm 10\%$) (μm) ^{1,3}	16	12
Resolution, x, y (μrad) ²	0.004	0.04
Resolution, Z (nm) ²	0.03	3
Typ. Repeatability, x, y (μrad)	NA	1.3
Typ. Repeatability, Z (nm)	NA	12
Capacitance ($\pm 20\%$) (μF)	1.8	1.8
Resonant frequency, unloaded (Hz)	5400	5400
Stiffness in Z (N/ μm)	65	65
Max load (N) ⁴	1	1
Weight (g)	85	85

¹ Typical value measured with NPC3 or NPC3SG (-20 V to +130 VDC range).

² Equal to rms noise value measured with NPC3 or NPC3SG controller.

³ Linear travel and angular travel are interdependent. The values provided here are for pure linear or pure angular motion.

⁴ Maximum load that can be applied in the direction of motion. For multi-axis systems, read as X/Y/Z.

⁵ NPC3 is used with PSM2 only and NPC3SG is used with PSM2SG only.



Model NPO250SG

NPO Series

- Sub-nanometer piezoelectric positioning resolution
- Piezoelectric travel range of 140 or 250 μm
- High resonant frequency for dynamic applications
- Precision parallelogram design minimizes beam offsets

The NPO Series Objective NanoFocusing stages are high-speed, piezoelectric-driven devices. They provide fast focusing and scanning over long travel ranges of up to 250 μm and are compatible with most microscopes and objective lenses. Typical applications include surface profilometry, high-resolution imaging, auto-focusing, scanning interferometry, and confocal microscopy.

NPO stages feature highly reliable, multi-layer, low-voltage, piezoelectric transducer (PZT) stacks, which are optimized for high-duty cycle operations. Image shifts and tilt are minimized by an FEA-modeled and precision EDM-cut parallelogram, solid-state flexure that ensures perfectly straight motion. The sophisticated guide also provides the highest possible stiffness for superior focus stability, higher frequency auto-focusing, shorter settling times and faster scans. NPO stages are maintenance-free and are not subject to wear.

NPO NanoFocusing stages are available as open-loop (no position feedback) or closed-loop versions with integrated position feedback. In open-loop, the resolution is only limited by the noise of the control electronics, but repeatability and stability are compromised due to the hysteresis and creep of the piezoelectric ceramic material. The closed-loop systems (model numbers ending in SG) feature high resolution strain-gauge position sensors for highly accurate and repeatable motion. Also, the position feedback compensates for actuator creep. For highest position stability and highest temperature-insensitive performance, the sensors are assembled in a full Wheatstone bridge design. The closed-loop devices can be operated in open or closed-loop control.

The NPO NanoFocusing stages mount between the turret and the microscope objective and add only 11.5 mm to the optical path length. All models can be used for standard and inverted microscopes. The standard thread size is W0.8x1/36" and is compatible with all Newport objective lenses. For other thread sizes, please contact Newport.

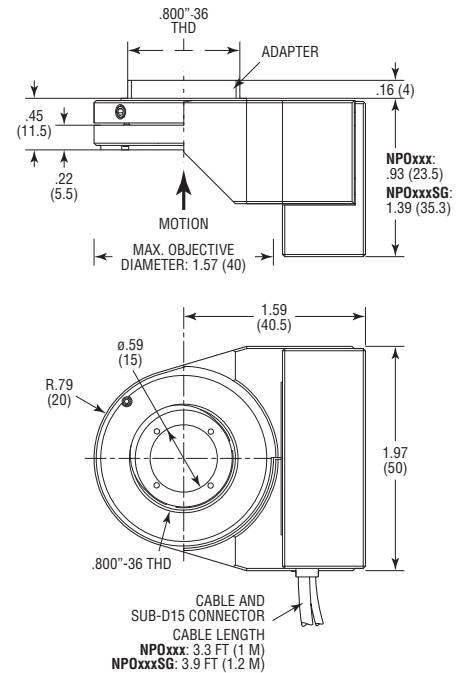

DIMENSIONS IN INCHES (AND MILLIMETERS)

Model	NPO100	NPO140	NPO250
Open loop travel per axis ($\pm 10\%$), (μm) ¹	100	140	250
Open loop resolution (nm) ²	0.2	0.3	0.5
Capacitance ($\pm 20\%$) (μF)	7.2	3.4	10.2
Resonant frequency, unloaded (Hz)	890	370	310
With 80 g load (Hz)	390	300	270
With 105 g load (Hz)	330	270	250
With 300 g load (Hz)	240	210	155
Axial stiffness (N/ μm)	1.4	1.4	0.4
Max lens weight (g)	300	500	500
Typ. Tilt, full travel (μrad)	<20	<4	<10
Weight (g)	105	150	255

Vacuum Model	NA	NA	NPO250V6
Vacuum Compatibility	-	-	10 ⁻⁶ Torr

¹ Typical value measured with NPC3 (-20 V to +130 VDC range).

² Equal to rms noise value measured with NPC3 controller.

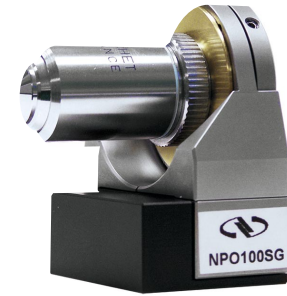

Microscope objective mounted on a NPO100 stage.

Model	NPO100SG	NPO140SG (-D)	NPO250SG (-D)
Closed loop travel per axis (μm) ^{1,2}	80	100	200
Closed loop resolution (nm) ²	2	3	5
Typ. Repeatability (nm) ²	6	30	46
Capacitance ($\pm 20\%$) (μF)	7.2	3.4	10.2
Resonant frequency, unloaded (Hz)	890	370	310
With 80 g load (Hz)	390	300	270
With 105 g load (Hz)	330	270	250
With 300 g load (Hz)	240	210	155
Axial stiffness (N/ μm)	1.4	1.4	0.4
Max lens weight (g)	300	500	500
Typ. Tilt, full travel (μrad)	<20	<4	<10
Weight (g)	150	150	255

Vacuum Model	NA	NA	NPO250SGV6
Vacuum Compatibility	-	-	10 ⁻⁶ Torr

¹ Typical value measured with NPC3SG, (-20 V to +130 VDC range).

² Applies to devices ending with SG in closed-loop control only.

Mount to Microscope

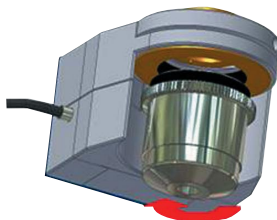

1 Screw the microscope objective into the NPO NanoFocusing stage .

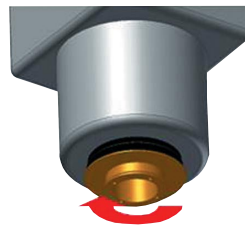

2 Screw the adapter into the microscope.

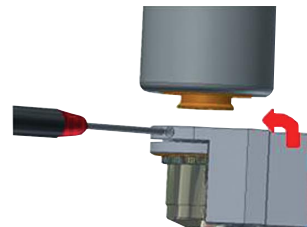

3 Clamp to NPO NanoFocusing stage on the adapter.

Piezo Stack Controllers and Drivers

NPC Series



NPxxx Series are driven with the NPC3/NPC3SG 3-Channel Piezo Amplifier

The NPC3 is a 3-channel piezo amplifier for precision control of all Newport NanoPositioning products and other low voltage PZTs. Optimized for usability and versatility, these low-noise piezo amplifiers can supply a permanent current of 40 mA per channel in a voltage range of -20 VDC to 130 VDC. The model NPC3 can operate in open-loop only and doesn't read feedback from strain gauges. Use this NPC for all NanoPositioning products not ending with SG.

The NPC3SG can operate in closed-loop and provides feedback from strain gauge models ending with -SG.

- Compact, 3-channel piezoelectric amplifier
- Manual, analog and computer control
- RS232 and USB interface
- Low-noise voltage output (0.3 mV rms@500 Hz)
- QVGA color display

Model	Description
NPC3	3-channel piezo stack amplifier, open-loop control
NPC3SG	3-channel piezo amplifier, strain-gauge position control

Note: NPxxxx (without -D or -SG) is compatible with NPC3. NPAxxx-SG is compatible with NPC3SG.

XPS Series



NPxxx Series are compatible with XPS Multi-Axis High-Performance Motion Controller/Driver. Just add "-D" to the end of the part number.

- High performance, 1-8 axes motion controller for steppers, DC servos, brushless motors, piezoelectric stacks, voice coils and other motors
- High-speed 10/100 Base-T Ethernet TCP/IP communication interface
- Advanced 8 KHz servo loop with variable PID's, low-pass and notch filters, linear error compensation and 3D error mapping
- High speed data acquisition and event triggers for process development and synchronization

Model	Description
XPS-Qx	x-Axis Universal Controller/Driver, ethernet
XPS-DRVP1	NanoPositioning drive module for piezo-stack based products

Note: XPS is compatible only with NPxxx-D models. XPS-DRVP1 is required for each axis.

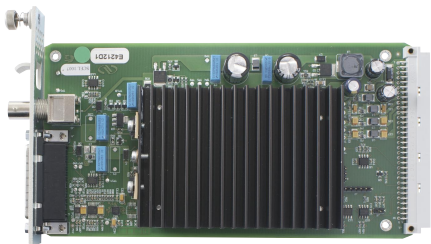

OEM SOLUTIONS

New Focus has designed and manufactured high precision mechanical and piezo motion components for both the OEM and research markets. The depth of our mechanical, optical, and electronics engineering capabilities has made us a recognized leader in precision motion control and high quality opto-mechanical components. Over the years, we have gained considerable experience in multi-national manufacturing with development and manufacturing operations in China and France, as well as at various sites in North America. Our ability to formalize and document designs clearly, our quality-conscious volume manufacturing procedures, and our efficient materials handling capabilities have led to our success as a multi-national manufacturer. All our operating practices are kept current and are regularly audited as part of our ISO certification.



People Dedicated to OEM

Our employees make New Focus a truly great OEM partner – in addition to our state of the art clean room facility, the thousands of calibrated instruments and measurement tools, and the broad range of CAD and FEA tools available for products design. From your initial contact with our sales and customer-service teams, you will be working with people who are committed to meeting your needs. Our experienced teams understand the technology, cost, and schedule requirements of the OEM business. Our marketing and engineering managers work closely with you to ensure the appropriate disciplines are applied to review your project requirements. Our goal is to always provide complete and detailed responses that meet your schedule, not ours.



Rely on Our Engineering Expertise

We have a broad understanding of motion control and the ability to integrate solutions with electronics enables us to approach your OEM project from a unique angle. We have demonstrated track record of success with leading OEM's – along with extensive in-house design and design analysis tool. To keep communications straight forward and open, engineers are an integral part of our OEM team: during the initial discussion to understand the scope of your problems and any issues that you may have; through the design revisions to the fine tune solutions; for the delivery of prototypes and any further design iterations; and finally to work with our manufacturing team so that production can ramp up quickly and efficiently. Rest assure non-disclosure agreements are setup from the very beginning to ensure strict confidentiality.

By applying rigorous engineering standards from start to finish we deliver thoroughly engineered and tested OEM solutions that will exceed your specifications and expectations.

Engineering Tools Include:

Mechanical Design Analysis

- Thermal distortion of assemblies
- Shock and vibration analysis
- Strength and stability analysis

Design Tools

- 3D Solid Models – Solidworks
- AutoCAD
- Pro/E
- Zemax
- CADKEY
- MicroStation

Material Qualification

- GCMS Outgassing testing

Three Types of OEM Business

Our OEM team is here to work with you whether you need:

- 1) Minor or major modifications of your existing catalog products (assuring ECO configuration control)
- 2) Customized solutions from design to development and manufacturing
- 3) Contract manufacturing services for build to print



Quality Systems

New Focus employs an ANSI/ISO/ASOC ISO 9001 – compliant quality system that has enabled us to provide best-in class products, quality volume manufacturing, excellent RMA performance, and superior on-time delivery. Highlights of the ISO 9001 compliant/registered quality and business systems include:

- Product development process
- Centralized and electronic document control system
- Engineering change control
- Deviation process
- Engineering review board activities
- Quality inspection techniques
- Receiving inspection
- In-process quality control
- Statistical process control and analysis
- On-going product reliability analysis
- Finished-goods source inspection
- Supplier evaluations/controls
- Centralized calibration database and service
- Internal and external quality system assessments

Products to Highlight

OEM XYZ Stage

Part of our specialty is the ability to customize products specifically for our commercial customers. For instance, we have built custom X, Y, Z Picomotor stages in a small footprint for use in a beam alignment application for life and health sciences systems. In this application, Picomotor products were used to provide X, Y, and Z translation in an optical medical application to align laser light source into a fiber for higher powers. However due to space constraints, the real challenge is to ensure the solution fits into current system design with a set and forget technology.

If you have special application where you need special material, please contact us.

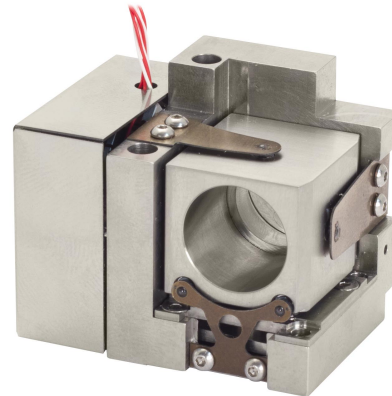

Specifications

- Motorized Axes: 3
- Axes of Travel: X, Y, Z
- Travel Range X, Y, Z: 0.75 mm
- Minimum Incremental Motion (X, Y, Z): <30 nm
- Load Capacity: 3 lb (13 N)
- Operating Temperature: 10 to 40 °C
- Survival Temperature Range (non-operating): -40 to 85 °C

Maximizing the Lifetime of Your Picomotor™ Actuators

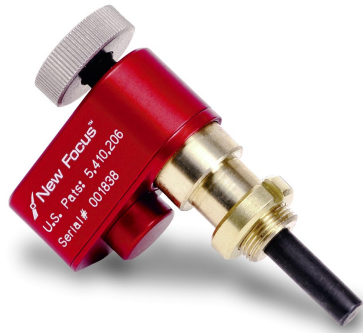

In order to achieve consistent performance and maximize the lifetime of your Picomotor™ actuators, keep the following precautions in mind:

Do not remove the knob or the screw from the housing.

The knob is an integral piece of the Picomotor actuator, and its inertia plays an important part in the stick-slip motion of the Picomotor actuator.

If the motor stalls, carefully turn the actuator using the knob.

Stalling may occur as the Picomotor actuator ages. By turning the knob and working the screw across the “offending” thread region, the Picomotor actuator can “self heal.”

If the motor hits a stop, turn off the driver as soon as possible.

Running the Picomotor actuator against a hard stop will decrease the lifetime but will not cause immediate irreparable damage.

Lubricate point of contact

Use a small amount of lubricant between the stainless-steel ball tip and the load surface to prevent wear and the generation of debris in the interface. We recommend Krytox GPL 205 or the low-vapor pressure grease, LVP LCT-42.

Clean point of contact

Keep the interface between the stainless-steel ball tip and the load surface clean of debris. Even small particles on the order of a micron can make a difference in the repeatability and torsional load of the actuator.

Contact point

Push against smooth, hard, flat surfaces only, such as the sapphire pads used in New Focus™ mirror mounts and translation stages. Pushing on aluminum or stainless-steel surfaces will wear out the ball tip. If the load surface is too soft, small amounts of material can build up in the interface between the ball tip and load surface resulting in surface roughness which can degrade repeatability.

Do not push against cone or v-shapes, especially in softer materials such as aluminum. When the ball wears against a cone or v-shape in softer materials, particle generation can lead to increased friction and torsional loads. These torsional loads can easily exceed the torsional load limit of 2.5 oz-in (0.018 N•m) thus stalling the motor.

Avoid damage to the screw threads

Do not touch the screw threads with any hard object – even lightly. Through careful control over the screw and nut thread manufacturing process, we can enable high quality performance. To provide the fine resolution, the screw has very fine-pitch threads. If the threads are damaged, this damaged area will produce repeated excessive wear within the fixed motor housing and significantly reduce the lifetime of the motor.

Avoid clamping tightly on the motor’s housing

This can cause increased friction between the rotating inner screw and the fixed exterior housing resulting in slowed motor motion or complete failure. This can also result in damaged screw threads.

Periodically examine the stainless-steel ball tip and the load surface for wear.

Following these guidelines will help minimize any damage to the device or introduction of debris in the nut cavity, which is a primary driver of premature actuator failure. Please feel free to contact us if you have any questions.

Definitions of Picomotor Characteristics

Angular resolution

The smallest rotation you can make with the Picomotor™ actuator. This is the typical rotation caused by applying a single voltage pulse to the Picomotor actuator. Since the Picomotor actuator relies on friction to turn the screw (it's a stick-slip actuator), the actual angle change per pulse varies a small amount with the direction of rotation, load, temperature, and wear of the unit. We typically observe variations of a few percent (or less) in angle change per pulse, while moving in one direction at a constant load and temperature.

Angular travel

The maximum total change in the angle of the mounting plate relative to the base in our motorized stages.

Degrees of freedom

The total number of translation directions plus rotation directions that you can change by rotating the adjustment screws on our mounts and stages (whether motorized or not).

Flip-to-Flip repeatability

The difference in angular position between consecutive flips.

Holding force

The amount of force exerted by the motors to keep the position of the stage.

Lifetime

The total number of steps that the motor can be continuously operated at the indicated pulse repetition rate.

For the Picomotor actuators there is a linear relationship between lifetime and pulse repetition rate; running the motors at a slower rate will result in a proportionally longer life.

Linear travel

The maximum possible Picomotor actuator translation. This is limited only by the length of the Picomotor actuator's screw.

Maximum load

For the Picomotor actuator, the maximum weight the stage can handle. The force that the Picomotor actuator or stage (or Picomotor actuator-equipped mount or stage) can exert before stalling. Since the Picomotor actuator and closed-loop stages depend on friction to move, large loads can prevent the actuator from moving at all. As the maximum load on a Picomotor actuator is approached, the typical step size is decreased. (See graph below.) For closed-loop stages, the maximum load is the load the stage can hold and still move.

Minimum incremental motion

The smallest translation/rotation you can make.

Motorized axes

Of the possible degrees of freedom of the mount or stage, the number that are motorized.

Operating temperature

Our specifications are guaranteed only in this temperature range. If your application demands high- or low-temperature operation, call us for more information.

Speed

For linear positioners, this is the Picomotor actuator's translation rate with no load; for the rotary, it is the rotation rate. The speed of the device is directly related to the rate at which pulses are applied, the minimum angular resolution, and, in the case of linear positioners, the screw thread pitch. We calculated speed assuming a pulse rate of 1 kHz, which all our drivers can produce.

Step size

The typical translation caused by applying a single voltage pulse to the Picomotor actuator. Since the Picomotor actuator relies on friction to turn a screw, the step size will vary slightly from pulse to pulse. (See "Angular Resolution" for more information.)

Torque

The torque that the Picomotor actuator can exert before stalling. Since the Picomotor actuator depends on friction to move, overloads can prevent the actuator from moving at all. As maximum torque load is approached, typical step size decreases.

Total repeatability

The difference in angular position between the first flip and the 10,000th flip.

Typical accuracy

A measure of the degree to which a given displacement matches a standard.

Typical bi-directional repeatability

A measure of how well the device returns to a set position over many attempts and when approached from either direction.



www.newport.com/newfocus

3635 Peterson Way, Santa Clara, CA 95054, USA

PHONE: 1-800-222-6440 1-408-980-4300 FAX: 1-408-919-6083 EMAIL: sales@newfocus.com

	PHONE	EMAIL		PHONE	EMAIL
Belgium	+32-(0)0800-11 257	belgium@newport.com	Irvine, CA, USA	+1-800-222-6440	sales@newport.com
China	+86-10-6267-0065	china@newport.com	Netherlands	+31-(0)30 6592111	netherlands@newport.com
France	+33-(0)1-60-91-68-68	france@newport.com	United Kingdom	+44-1235-432-710	uk@newport.com
Japan	+81-3-3794-5511	spectra-physics@splasers.co.jp	Germany / Austria / Switzerland	+49-(0)6151-708-0	germany@newport.com
Taiwan	+886 -(0)2-2508-4977	sales@newport.com.tw			

Newport Corporation, Irvine, California and Franklin, Massachusetts; Evry and Beaune-La-Rolande, France and Wuxi, China have all been certified compliant with ISO 9001 by the British Standards Institution. Santa Clara, California is DNV certified.

Newport Corporation, Global Headquarters
1791 Deere Avenue, Irvine, CA 92606, USA

PHONE: 1-800-222-6440 1-949-863-3144
EMAIL: sales@newport.com

Complete listings for all global office locations are available online at www.newport.com/contact