



XPS-RLD

Universal High-Performance Motion Controller/Driver



Start-Up Manual

Warranty

Newport Corporation warrants that this product will be free from defects in material and workmanship and will comply with Newport's published specifications at the time of sale for a period of one year from date of shipment. If found to be defective during the warranty period, the product will either be repaired or replaced at Newport's option.

To exercise this warranty, write or call your local Newport office or representative, or contact Newport headquarters in Irvine, California. You will be given prompt assistance and return instructions. Send the product, freight prepaid, to the indicated service facility. Repairs will be made and the instrument returned freight prepaid. Repaired products are warranted for the remainder of the original warranty period or 90 days, whichever occurs last.

Limitation of Warranty

The above warranties do not apply to products which have been repaired or modified without Newport's written approval, or products subjected to unusual physical, thermal or electrical stress, improper installation, misuse, abuse, accident or negligence in use, storage, transportation or handling.

THIS WARRANTY IS IN LIEU OF ALL OTHER WARRANTIES, EXPRESSED OR IMPLIED, INCLUDING ANY IMPLIED WARRANTY OF MERCHANTABILITY OR FITNESS FOR A PARTICULAR USE. NEWPORT CORPORATION SHALL NOT BE LIABLE FOR ANY INDIRECT, SPECIAL, OR CONSEQUENTIAL DAMAGES RESULTING FROM THE PURCHASE OR USE OF ITS PRODUCTS.

©2019 by Newport Corporation, Irvine, CA. All rights reserved.

Original instructions.

No part of this document may be reproduced or copied without the prior written approval of Newport Corporation. This document is provided for information only, and product specifications are subject to change without notice. Any change will be reflected in future publishings.

Table of Contents

	Waranty.....	ii
	EU Declaration of Conformity.....	vi
	Preface	viii
1.0	Introduction	1
1.1	Scope of the Manual	1
1.2	Definitions and Symbols.....	1
1.2.1	General Warning or Caution	1
1.2.2	Electric Shock	2
1.2.3	European Union CE Mark.....	2
1.2.4	“ON” Symbol.....	2
1.2.5	“OFF” Symbol	2
1.2.6	Protective Earth Symbol	2
1.3	Warning, Caution and Note Definition	3
1.4	General Warnings and Cautions.....	3
2.0	System Overview	5
2.1	Specifications	5
2.2	Drive Options.....	7
2.3	Compatible Newport Positioners and Drive Power Consumption	7
2.4	Front Panel Description	8
2.5	Rear Panel Description.....	9
2.5.1	Axis Connectors (AXIS 1 – AXIS 4).....	9
2.6	Ethernet Configuration.....	10
2.6.1	Communication Protocols.....	10
2.6.2	Addressing	10
2.7	Sockets, Multitasking and Multi-user Applications	10
2.8	Programming with TCL.....	11
3.0	Getting Started	12
3.1	Unpacking and Handling	12
3.2	Inspection for Damage.....	12
3.3	Packing List	12
3.4	System Setup.....	12
3.4.1	Rack Mounting Kit.....	13
3.4.2	Installing Driver Cards.....	14
3.4.3	Connecting to the Main.....	15
3.4.4	Power ON.....	16

3.5	Connecting to the XPS	16
3.5.1	Direct Connection to the XPS Controller.....	17
3.5.2	Connecting the XPS to a Corporate Network Using Static IP Configuration	20
3.5.3	Configuring the XPS for Connection to a Corporate Network Using Dynamic IP Configuration	21
3.5.4	Recovering a Lost IP Configuration.....	23
3.5.5	Testing your XPS-PC Connection and Communication	24
3.6	Connecting the Stages.....	26
3.7	Configuring the Controller.....	26
3.8	Using the Controller.....	26
3.9	Documentation	27
3.10	SFTP (Secured File Transfer Protocol) Connection.....	27
3.11	Samba Microsoft SMB/CIFS Networking Protocol.....	29
3.12	System Shut-Down	29
4.0	Maintenance and Service.....	30
4.1	Enclosure Cleaning	30
4.2	Obtaining Service.....	30
4.3	Troubleshooting	30
5.0	Appendix A: Hardware.....	31
5.1	Controller	31
5.3	Controller with Rack Mounting Kit	32
5.3.1	Front Rack Mounting	32
5.3.2	Rear Rack Mounting	32
5.4	Rear Panel Connectors	33
6.0	Appendix B: General I/O Description.....	34
6.1	Digital I/O (GPIO1)	34
6.1.1	Digital Inputs.....	34
6.1.2	Digital Outputs	35
6.1.3	GPIO1 Connector.....	36
6.2	Analog I/O (GPIO2)	37
6.2.1	Analog Inputs.....	37
6.2.2	Analog Outputs	37
6.2.3	GPIO2 Connector.....	37
6.3	Digital Encoder Inputs (Driver Boards & DRV00P)	38
6.4	Digital Servitudes (Driver Boards, DRV00P & Analog Encoders Connectors)	38
6.5	Analog Encoder Inputs (Analog Encoder Connectors).....	38
6.5.1	Analog Encoder Connector	38
7.0	Appendix C: Power Inhibit Connector	40
7.1	Description.....	40

8.0	Appendix D: PCO Connector.....	41
8.1	Description.....	41

9.0	Appendix E: Motor Driver Cards.....	43
9.1	Universal digital DC, Stepper and Direct Drive Motor Driver XPS-DRV11	43
9.2	Piezoelectric Motor Driver XPS-DRVP1	44
9.3	DC and Stepper Motor Driver XPS-DRV01	45
9.4	Three phase AC Brushless Driver XPS-DRV02.....	47
9.5	DC Motor Driver XPS-DRV03.....	47
9.6	Pass-Through Board XPS-DRV00P	48

Service Form	49
---------------------------	-----------

EU Declaration of Conformity



EU Declaration of Conformity

Application of Council Directive(s):

- Electromagnetic Compatibility Directive (EMCD) - 2014/30/EU
- Low Voltage Directive (LVD) - 2014/35/EU
- European Pressure Equipment Directive (PED) - 2014/68/EU
- Machinery Directive - 2006/42/EC
- Restriction of Hazardous Substances Directive (RoHS) – 2011/65/EU ⁽⁷⁾

Standard(s) to which conformity is declared:

- EN 61326-1:2013 - (EMC)
- EN 61326-2-3:2013 - (EMC)
- EN 61010-1:2010 + AMD 1:2016 (Ed 3) – (Safety)
- EN 60825-1:2014 Safety of Laser products - Part 1: Equipment classification and requirements
- PED Module SEP (Sound Engineering Practices): 2014

Manufacturers Name: MKS Instruments, Inc. Andover, MA, USA

Importer's Name & Location: /

Equipment Type/Description: **Universal High-Performance Motion Controller/Driver**

Model Number(s) ⁽⁶⁾: **XPS-RLDM; XPS-RLD2; XPS-RLD4**

MKS confirms that, with respect to the products listed above, it believes it is in conformity with the selected European Union harmonization legislation – noted on the attached page of this document. MKS product conforms to the above Directive(s) and Standard(s) only when installed in accordance with manufacturer's specifications. This declaration has been issued under the sole responsibility of the manufacturer.

Date: 12/18/2019

Le Cointe Hervé – Quality Director



Test Specification Listing

Emissions:

- CISPR 11:2015 Industrial, Scientific and Medical Equipment Radio-Frequency Disturbance Characteristics - Limits and Methods of Measurement
- IEC 61000-3-2:2018 EMC/Limits for Harmonic Current Emission ⁽¹⁾
- IEC 61000-3-3:2013 + AMD1:2017 EMC/Limitations of Voltage Fluctuations and Flicker in Low-Voltage Supply Systems ⁽²⁾
- IEC 61000-3-3:2013 + AMD1:2017 EMC/Limitations of Voltage Fluctuations and Flicker in Low-Voltage Supply Systems ⁽³⁾
- EN 55011: 2016 + A1:2017 ⁽⁴⁾ Industrial, scientific and medical equipment - Radio-frequency disturbance characteristics - Limits and methods of measurement
- EN 55032:2015 Electromagnetic compatibility of multimedia equipment - Emission Requirements
- IEC 61000-6-4 (2018) Emission standard for industrial environments
- FCC 47 CFR Part 18: 2018
- FCC Part 15 class A

Immunity:

- IEC 61000-4-2:2008 EMC/Electrostatic Discharge Immunity Test
- IEC 61000-4-3:2006 2006+AMD1:2007+AMD2:2010 EMC/Radiated Radio - Frequency Electromagnetic Field Immunity Test
- IEC 61000-4-4:2012 EMC/Electrical Fast Transient/Burst Immunity Test
- IEC 61000-4-5:2014 + AMD 1:2017 EMC/Surge Immunity Test ⁽⁵⁾
- IEC 61000-4-6:2013 EMC/Conducted Disturbances induced by Radio Frequency Fields Immunity Test
- IEC 61000-4-8:2009 EMC/Power Frequency Magnetic Field Immunity Test
- IEC 61000-4-11:2004 + AMD 1:2017 EMC/Voltage Dips, Short Interruptions and Variations Immunity Test ⁽⁵⁾
- IEC 61000-4-34:2005+AMD1:2009 EMC/Voltage Dips, Short Interruptions and Variations Immunity Test ⁽⁵⁾
- IEC 61000-6-2 (2016) Immunity standard for industrial environments

Machinery EN Standard(s):

- EN ISO 12100:2010 Safety of Machinery – General Principles of Design – Risk Assessment and Risk Reduction
- EN 60204-1:2006 Safety of Machinery – Electrical Equipment of Machines - Part1: General Requirements
- EN 60204-33:2010 Safety of Machinery – Electrical Equipment of Machines – Part 33: Requirements for Semiconductor Fabrication Machinery
- EN ISO 13849-1:2008 Safety of Machinery – Safety Related Parts of Control Systems – Part 1: General Principles for Design
- EN ISO 11553-1:2008 Safety of Machinery- Laser Processing Machinery – Part 1: General Safety Requirements

Safety:

- IEC 60825-1:2014 Safety of Laser Products - Part 1: Equipment classification and requirements
- IEC 62471: 2006 Photobiological Safety of Lamps and Lamp Systems

-
- 1) Applicable to AC powered product only. Class B
 - 2) Applicable to AC powered product; DC powered connections must not connect to a D.C. distribution network; I/O Signal and Control Lines must be less than 30m and not exit the building.
 - 3) Applicable to AC powered product; DC powered connections and may connect to a D.C. distribution network.
 - 4) Class A, Group 2
 - 5) Applicable to AC powered product only.
 - 6) Compliance of the above model numbers requires the use of a braided shielded cable properly terminated at both ends – if so noted in the MKS Instruction Manual
 - 7) RoHS Directive has to be checked for in scope products; cannot CE mark without compliance to RoHS. RoHS Directive can be unchecked only for systems which MKS sells which qualify for “Large Scale Industrial Tool” exclusion.

Preface

Confidentiality & Proprietary Rights

Reservation of Title

The Newport Programs and all materials furnished or produced in connection with them ("Related Materials") contain trade secrets of Newport and are for use only in the manner expressly permitted. Newport claims and reserves all rights and benefits afforded under law in the Programs provided by Newport Corporation.

Newport shall retain full ownership of Intellectual Property Rights in and to all development, process, align or assembly technologies developed and other derivative work that may be developed by Newport. Customer shall not challenge, or cause any third party to challenge, the rights of Newport.

Preservation of Secrecy and Confidentiality and Restrictions to Access

Customer shall protect the Newport Programs and Related Materials as trade secrets of Newport, and shall devote its best efforts to ensure that all its personnel protect the Newport Programs as trade secrets of Newport Corporation. Customer shall not at any time disclose Newport's trade secrets to any other person, firm, organization, or employee that does not need (consistent with Customer's right of use hereunder) to obtain access to the Newport Programs and Related Materials. These restrictions shall not apply to information (1) generally known to the public or obtainable from public sources; (2) readily apparent from the keyboard operations, visual display, or output reports of the Programs; (3) previously in the possession of Customer or subsequently developed or acquired without reliance on the Newport Programs; or (4) approved by Newport for release without restriction.

Sales, Tech Support & Service

North America & Asia

Newport Corporation
1791 Deere Ave.
Irvine, CA 92606, USA

Sales

Tel.: (800) 222-6440
e-mail: sales@newport.com

Technical Support

Tel.: (800) 222-6440
e-mail: tech@newport.com

Service, RMAs & Returns

Tel.: (800) 222-6440
e-mail: service@newport.com

Europe

MICRO-CONTROLE Spectra-Physics S.A.S
9 rue du bois sauvage
91055 Évry CEDEX
France

Sales France

Tel.: +33 (0)1.60.91.68.68
e-mail: france@newport.com

Sales Germany

Tel.: +49 (0) 61 51 /708 – 0
e-mail: germany@newport.com

Sales UK

Tel.: +44 (0)1635.521757
e-mail: uk@newport.com

Technical Support

e-mail: tech_europe@newport.com

Service & Returns

Tel.: +33 (0)2.38.40.51.55

Service Information

The user should not attempt any maintenance or service of the XPS Series Controller/Driver system beyond the procedures outlined in this manual. Any problem that cannot be resolved should be referred to Newport Corporation. When calling Newport regarding a problem, please provide the Tech Support representative with the following information:

- Your contact information.
- System serial number or original order number.
- Description of problem.
- Environment in which the system is used.
- State of the system before the problem.
- Frequency and repeatability of problem.
- Can the product continue to operate with this problem?
- Can you identify anything that may have caused the problem?

Newport Corporation RMA Procedures

Any XPS Series Controller/Driver being returned to Newport must be assigned an RMA number by Newport. Assignment of the RMA requires the item's serial number.

Packaging

XPS Series Controller/Driver being returned under an RMA must be securely packaged for shipment. If possible, re-use the original packaging.



Universal High-Performance Motion Controller/Driver XPS-RLD Controller

1.0 Introduction

1.1 Scope of the Manual

The XPS-RLD is an extremely high-performance, easy to use, integrated motion controller/driver offering high-speed communication through 10/100/1000 Base-T Ethernet, outstanding trajectory accuracy and powerful programming functionality. It combines user-friendly web interfaces with advanced trajectory and synchronization features to precisely control from the most basic to the most complex motion sequences. Multiple digital and analog I/O's, triggers and supplemental encoder inputs provide users with additional data acquisition, synchronization and control features that can improve the most demanding motion applications.

To maximize the value of the XPS Controller/Driver system, it is important that users become thoroughly familiar with available documentation.

The present **XPS-RLD Start-Up Manual** is delivered as a hard copy with the controller.

Start-Up Manual, User Interface Manual, Features Manual, Configuration Manual and Unified Programmer's Manual are PDF files accessible from the controller disk which can be downloaded from the controller website under the tab Documentation.

.NET assemblies and corresponding sources (including example) are available from the controller website under the tab Documentation -> Drivers.

LabVIEW VIs with examples are also available to download from the Newport website.

1.2 Definitions and Symbols

The following terms and symbols are used in this documentation and also appear on the XPS Series Controller/Driver where safety-related issues occur.

1.2.1 General Warning or Caution



Figure 1: General warning or caution symbol.

The Exclamation Symbol in Figure 1 may appear in Warning and Caution tables in this document. This symbol designates an area where personal injury or damage to the equipment is possible.

1.2.2 Electric Shock



Figure 2: Electrical shock symbol.

The Electrical Shock Symbol in Figure 2 may appear on labels affixed to the XPS Series Controller/Driver. This symbol indicates a hazard arising from dangerous voltages. Any mishandling could result in damage to the equipment, personal injury, or even death.

1.2.3 European Union CE Mark



Figure 3: CE mark.

The presence of the CE Mark on Newport Corporation equipment means that it has been designed, tested and certified to comply with all current and applicable European Union (CE) regulations and recommendations.

1.2.4 “ON” Symbol



Figure 4: “ON” symbol.

The “ON” Symbol in Figure 4 appears on the power switch of the XPS Series Controller/Driver. This symbol represents the “Power On” condition.

1.2.5 “OFF” Symbol



Figure 5: “OFF” symbol.

The “Off” Symbol in Figure 5 appears on the power switch of the XPS Series Controller/Driver. This symbol represents the “Power Off” condition.

1.2.6 Protective Earth Symbol



Figure 6: Protective Earth symbol.

The Protective Earth Symbol in Figure 6 appears next to the ground stud at the rear of the XPS Series Controller/Driver.

1.3 Warning, Caution and Note Definition

The following are definitions of the Warnings, Cautions and Notes that may be used in this manual to call attention to important information regarding personal safety, safety and preservation of the equipment, or important tips.



WARNING

Situation has the potential to cause bodily harm or death.



CAUTION

Situation has the potential to cause damage to property or equipment.

NOTE

Additional information the user or operator should consider.

1.4 General Warnings and Cautions

The following general safety precautions must be observed during all phases of operation of this equipment.

Failure to comply with these precautions or with specific warnings elsewhere in this manual violates safety standards of design, manufacture, and the intended use of the equipment.

- Only properly trained personnel should use this device
- Heed all warnings on the unit and in the operating instructions.
- To prevent damage to the equipment, read the instructions in this manual for the selection of the proper input voltage.
- Use only the provided plug and the main cable specified for this product and certified for the country of use.
- Ensure that the equipment is properly grounded to earth ground through the grounding lead of the AC main cable.
- Route cables where they are not likely to be damaged.
- Keep permanent access to the wall inlet or to the main switching device.
- The system must be installed in such a way that the power switch and the power connector at the rear remain accessible to the user.
- Disconnect or do not plug-in the AC power cord under the following conditions:
 - If the AC power cord or any other attached cables are frayed or damaged.
 - If the power plug or receptacle is damaged.
 - If the unit is exposed to rain or excessive moisture, or liquids are spilled on it.
 - If the unit has been dropped or the case is damaged.
 - If the user suspects service or repair is required.
- Keep air vents free of dirt and dust and obstructions.
- Keep liquids away from unit.
- Do not expose equipment to moisture exceeding specification.
- Do not operate this equipment in an explosive atmosphere.
- Disconnect power before cleaning the Controller/Driver unit. Do not use liquid or aerosol cleaners.

- Do not open the XPS Controller/Driver stand-alone motion controller. There are no user-serviceable parts inside the XPS Controller/Driver.
- Return equipment to Newport Corporation for service and repair.
- Dangerous voltages associated with the power supply are present inside Controller/Driver unit. To avoid injury, do not touch exposed connections or components while power is on.
- Follow precautions for static-sensitive devices when handling electronic circuits.

WARNING

This product is equipped with a 3-wire grounding type plug. Any interruption of the grounding connection can create an electric shock hazard. If you are unable to insert the plug into your wall plug receptacle, contact an electrician to perform the necessary alterations to ensure that the green (green-yellow) wire is attached to earth ground.

System earthing must be of type earthed neutral (TN-) as defined by CEI60364.

WARNING

This product does not fulfill the requirements of CEI 61010-1:2010 §8.1 & 8.2.2 for impact test with energy level > 2J. Hence, precautions should be taken to prevent any shock higher than 2J on the controller enclosure.

2.0 System Overview

2.1 Specifications

Number of Axes	<ul style="list-style-type: none"> • 1 to 4 axes of stepper, DC brush, DC brushless, linear or piezo motors using internal drives: XPS-RLDM: 1-axis; XPS-RLD2: 2-axis; XPS-RLD4: 4-axis. • Other motion devices using external third-party drives
Communication Interfaces	<ul style="list-style-type: none"> • Internet protocol TCP/IP • One Ethernet 10/100/1000 Base-T (RJ45 connector) with fixed IP address and DHCP server for local communication • One Ethernet 10/100/1000 Base-T (RJ45 connector) for networking, dynamic addressing with DHCP and DNS • Typically 0.3 ms from sending a tell position command to receiving the answer
Firmware Features	<ul style="list-style-type: none"> • Powerful and intuitive, object-oriented command language • Native user-defined units (no need to program in encoder counts) • Real-time execution of custom tasks using TCL scripts • Multi-user capability • Concept of sockets for parallel processes • Distance spaced trigger output pulses, max. 1.6 MHz rate (5 MHz for less than 4096 pulses), programmable filter • Time spaced trigger output pulses, 0.05 Hz to 20 MHz, 5 ns accuracy • Trigger output on trajectories (depending on servo rate) • Data gathering up to 1,000,000 data entries (depending on servo rate) • User-defined “actions at events” monitored by the controller autonomously at the servo rate • User-definable system referencing with hardware position latch of reference signal transition and “set current position to value” capability • Axis position or speed controlled by analog GPIO input • Axis position, speed or acceleration copied to analog GPIO output • Trajectory precheck function replying with travel requirement and max. possible speed • Auto-configuration, auto-tuning and auto-scaling
Motion	<ul style="list-style-type: none"> • Jogging mode including on-the-fly changes of speed and acceleration • Synchronized point-to-point • Spindle motion (continuous motion with periodic position reset) • Line-arc mode (linear and circular interpolation incl. continuous path contouring) • Splines (Catmull-Rom type) • PVT (complex trajectory based on position, velocity and time coordinates) • Analog tracking (using analog input as position or velocity command) • Master-slave including single master-multiple slaves and custom gear ratio
Compensation	<ul style="list-style-type: none"> • Linear error, Backlash, positioner error mapping • XY and XYZ error mapping • All corrections are taken into account on the servo loop
Servo Rate	<ul style="list-style-type: none"> • 10 kHz
I/O	<ul style="list-style-type: none"> • 8 TTL inputs and 8 TTL outputs (open collector) • 2 synch. analog inputs ± 10 V, 12 bits • 2 synch. analog outputs ± 10 V, 12 bits

Control Loop	<ul style="list-style-type: none"> • Open loop, PI position, PIDFF velocity, PIDFF acceleration, PIDDualFF voltage • Variable PID's (PID values depending on distance to target position) • Deadband threshold; Integration limit and integration time • Derivative cut-off filter; 2 user-defined notch filters
Trigger In	<ul style="list-style-type: none"> • Hardware latch of all positions and all analog I/O's (on servo rate) • <50 ns latency on positions • <125 μs time jitter on analog I/O's
Trigger Out	<ul style="list-style-type: none"> • One high-speed Position Compare Output (Basic PCO), only for axes 1 and 2 that can be either configured for position synchronized pulses or for time synchronized pulses: 5 ns accuracy, <700 ns latency (from real stage position to pulse generation), 5 MHz max frequency • Interpolation x256 • Error compensated (except XY or XYZ mapping)
Dedicated Inputs Per Axis	<ul style="list-style-type: none"> • RS-422 differential inputs for A, B and I, Max. 25 MHz, over-velocity and quadrature error detection • 1 VPP analog encoder input up to x65536 interpolation used for servo; amplitude, phase and offset correction and synchronisation • Low noise encoder interpolator board for nanometer MIM • Forward and reverse limit, home, error input
Dedicated Outputs Per Axis (when using external drives)	<ul style="list-style-type: none"> • 2 channel 16-bit, ± 10 V • Drive enable, error output
Drive Capability	<ul style="list-style-type: none"> • Voltage, acceleration (used with XPS-DRV11 for DC brush motor control). • Position (used with XPS-DRV11 for stepper motor control) • Acceleration and velocity (used with XPS-DRV11 for linear motors control) • Analog piezo (used with XPS-DRVP1 for piezo motors control) • Analog position (used with XPS-DRV00P and external drives for example 3rd party motors) • Step and direction and \pm pulse mode for stepper motors (used with XPS-DRV00P and external stepper motor driver) • 300 W (@ 230 VAC) total available power
AC Power Requirements	<ul style="list-style-type: none"> • 100–240 VAC 60/50 Hz 9.5 A– 5.5 A. The controller should be connected to a power installation that incorporates appropriate protection devices. Refer to the installation requirements of your facility and local applicable Standards concerning the use of RCDs (residual current device).
Environmental Condition	<ul style="list-style-type: none"> • Internal use
Overvoltage Category	<ul style="list-style-type: none"> • Category II (2500 V max transient surges)
Operating Temperature	<ul style="list-style-type: none"> • +5 °C to +40 °C (Derate 1.5%/Degree above 40 °C)
Humidity	<ul style="list-style-type: none"> • 85% R.H. at 40 °C (Non-condensing)
Altitude	<ul style="list-style-type: none"> • Above 1000 m, derate at 1% per 100 m. Max. 2000 m
Storage Temperature	<ul style="list-style-type: none"> • -20 °C to +55 °C (Non-condensing)
Pollution	<ul style="list-style-type: none"> • Pollution Degree 2, exempt of conducting dust
Transport Temperature	<ul style="list-style-type: none"> • -20 °C to +70 °C (Non-condensing)

2.2 Drive Options

The XPS-RLD controller is capable of driving up to 4 axes of most Newport positioners using driver cards that slide through the back of the chassis. These factory-tested drives are powered by an internal power supply, which is independent of the controller power supply. When used with Newport ESP stages, the configuration of the driver cards is easy using the auto-configuration utility software. Advanced users can also manually develop their own configuration files optimized for specific applications.

NOTE

**The controller unit you get is limited to the number of axes you bought:
XPS-RLDM: 1-axis; XPS-RLD2: 2-axis; XPS-RLD4: 4-axis**

The XPS-DRV11 is a software configurable PWM amplifier that is compatible with most of Newport's and other companies' DC brush and stepper motor positioners.

The XPS-DRV11 motor driver supplies a maximum current of 2 x 3 Arms and 47 V. It has the capability to drive bipolar stepper motors in microstep mode (sine/cosine commutation).

It has been optimized for performance with XM, ILS-LM, IMS-LM linear motor stages and RGV direct drive rotation stages. It supplies a 78 kHz PWM output with a maximum output current of 6A peak per phase. It uses high resolution PWM technology and loiser noise phase-current measurement to enable ultra-precision positioning in the sub nm-range. The XPS-DRV11 requires 1 VPP analog encoder input signals used also for motor commutation. Motor initialization is done by a special routine measures the magnetic position without the need for Hall or other sensors.

The XPS-DRV11 has been optimized for use with high-performance DC motors. It is capable of driving DC motors in voltage mode and in current mode (for torque motors). All parameters are programmable in physical units. Furthermore, the XPS-DRV11 features individual limits for the rms current and the peak current.

The XPS-DRV00P pass-through module can be used to pass control signals to other external third-party amplifiers (drivers). By setting the controller's dual DAC output to either analog position, analog stepper position, analog velocity, analog voltage or analog acceleration (including sine commutation), the XPS is capable of controlling almost any motion device including 3rd party brushless motors and voice coils.

The XPS-DRVP1 is a programmable driver card for Newport's NanoPositioning line of piezoelectric stack stages. This driver card has a wide voltage range and accepts strain gage position feedback.

Users familiar with former XPS-DRV01, XPS-DRV02 and XPS-DRV03 driver cards must be aware these are still compatible with their new XPS-RLD controller.

In addition to conventional digital AquadB feedback encoder interface, the XPS controller also features a high-performance analog encoder input (1 VPP Heidenhain standard) on each axis. An ultra-high resolution, very low noise, encoder signal interpolator converts the sine-wave input to an exact position value with a signal subdivision up to 65536-fold. For example, when used with a scale with 4 μ m signal period the resolution can be as fine as 0.061 nm. This interpolator can be used for accurate position feedback on the servo corrector of the system or for synchronization purposes with an accuracy of 5 ns and a latency inferior to 700 ns from real stage position to pulse generation. Unlike most high-resolution multiplication devices, the XPS interpolators do not compromise positioning speed. With a maximum input frequency of 2.4 MHz, the maximum speed of a stage with a 20 μ m signal period scale can be up to 48 m/s.

2.3 Compatible Newport Positioners and Drive Power Consumption

The list of all compatible Newport positioners and the corresponding drive module needed is available from the Newport catalog or at www.newport.com

2.4 Front Panel Description

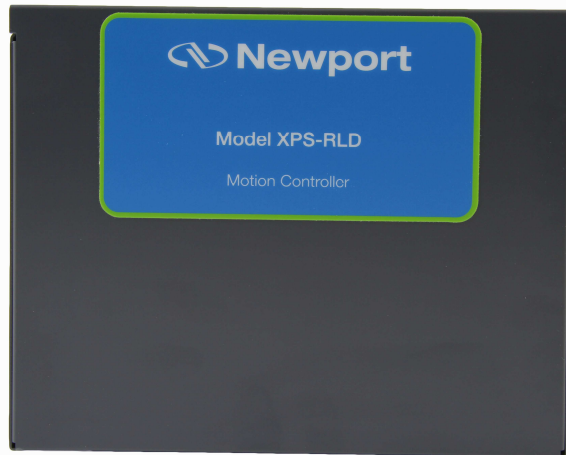

Figure 7: Front panel of XPS-RLD Controller/Driver.

The XPS-RLD front panel is free of any connection or command device.

2.5 Rear Panel Description

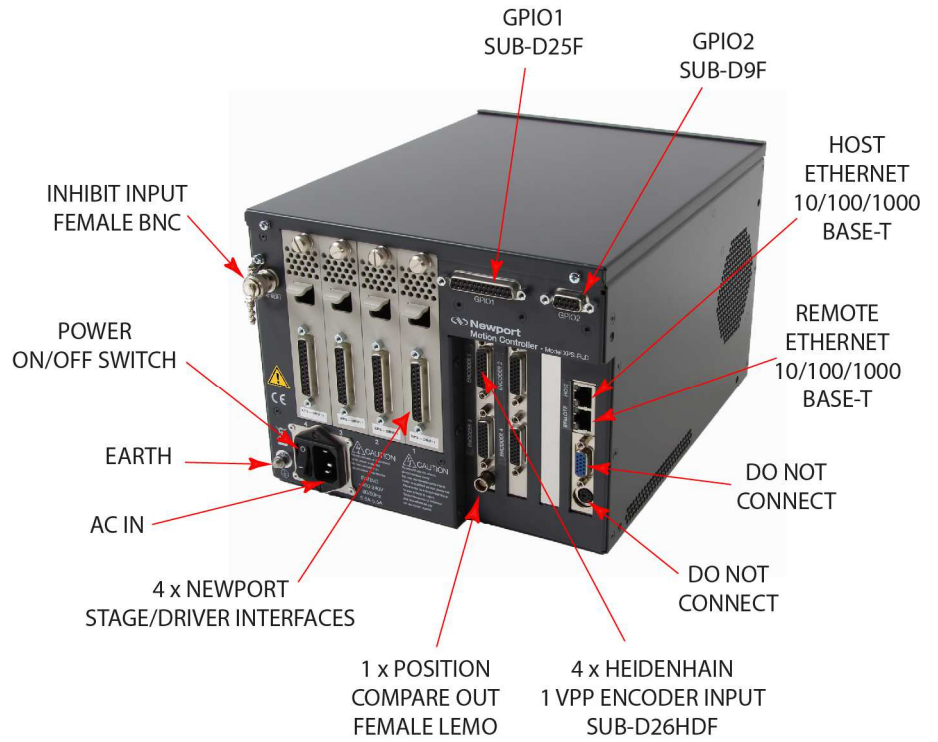

Figure 8: Rear panel of XPS-RLD Controller/Driver.

NOTE

The Main Power ON/OFF Switch is located next to the inlet for the power cord. The switch and the inlet must be accessible to the user.

2.5.1 Axis Connectors (AXIS 1 – AXIS 4)

Each installed axis driver card features a connector to attach a cable (supplied with every Newport stage) between the controller and a motion device.



Figure 9: Axis driver card.

Please see the next section for installation instructions.

2.6 Ethernet Configuration

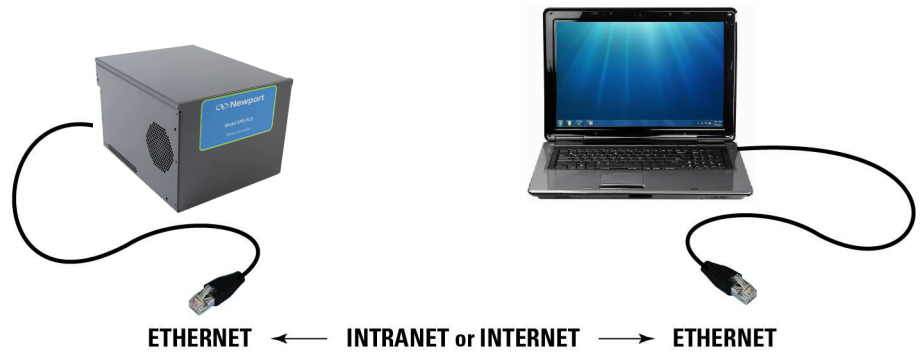

Figure 10: Ethernet configuration.

2.6.1 Communication Protocols

The Ethernet connection provides a local area network through which information is transferred in units known as packets. Communication protocols are necessary to dictate how these packets are sent and received. The XPS Controller/Driver supports the industry standard protocol TCP/IP.

TCP/IP is a “connection” protocol and in this protocol, the master must be connected to the slave in order to begin communication. Each packet sent is acknowledged when received. If no acknowledgment is received, the information is assumed lost and is resent.

2.6.2 Addressing

There are two levels of addresses that define Ethernet devices. The first is the MAC address. This is a unique and permanent 6 byte number. No other device will have the same MAC address. The second level of addressing is the IP address. This is a 32-bit (or 4 byte) number. The IP address is constrained by each local network and must be assigned locally. Assigning an IP address to the controller can be done in a number of ways (see section 3.5: “Connecting to the XPS”).

2.7 Sockets, Multitasking and Multi-user Applications

Based on the TCP/IP Internet communication protocol, the XPS controller has a high number of virtual communication ports, known as sockets. To establish communication, the user must first request a socket ID from the XPS controller server (listening at a defined IP number and port number). When sending a function to a socket, the controller will always reply with a completion or error message to the socket that has requested the action.

The concept and application of sockets have many advantages. First, users can split their application into different segments that run independently on different threads or even on different computers. To illustrate this, see below:

```

SocketID1=OpenSocket (...)
...
...
For i = 1 to nbpos
    Goal=Position (i)
    error=GroupMoveAbsolute (SocketID1, XY, goal)
    if error=OK than TakePicture
    ...
Next i
...

SocketID2=OpenSocket (...)
...
...
Zerror=ReadAFSensor
error=GroupMoveRelative (SocketID2, Z, Zerror)
...
    
```

In this example, a thread on socket 1 commands an XY stage to move to certain positions to take pictures while another thread on socket 2 independent of socket 1, concurrently manages an auto-focusing system. The second task could even be run on a

different PC than the first task yet be simultaneously executed within the XPS. Alternatively, if the auto-focusing system is providing an analog feedback, this task could have been implemented as a TCL script within the XPS (see the next topic).

Second, the concept of sockets has another practical advantage for many laboratory users since the use of threads allows them to share the same controller for different applications at the same time. With the XPS, it is possible that one group uses one axis of the XPS controller for an optical delay line, while another group simultaneously uses other axes for a totally different application. Both applications could run completely independent from different workstations without any delays or cross-talk.

The XPS controller uses TCP/IP blocking sockets, which means that the commands to the same socket are “blocked” until the XPS returns feedback about the completion of the currently executed command (either '0' if the command has been completed successfully, or an error code in case of an error). If customers want to run several processes in parallel, users can open as many as 80 parallel sockets.

2.8 Programming with TCL

TCL stands for Tool Command Language and is an open-source string based command language. With only a few fundamental constructs and relatively little syntax, it is very easy to learn, yet it can be as powerful and functional as traditional C language. TCL includes many different math expressions, control structures (if, for, foreach, switch, etc.), events, lists, arrays, time and date manipulation, subroutines, string manipulation, file management and much more. TCL is used worldwide with a user base approaching one million users. It is quickly becoming a standard and critical component in thousands of corporations. Consequently TCL is field proven, very well documented and has many tutorials, applications, tools and books publicly available (www.tcl.tk).

XPS users can use TCL to write complete application code and the XPS allows them to include any function in a TCL script. When developed, the TCL script can be executed in real time in the background of the motion controller processor and does not impact any processing requirements for servo updates or communication. The QNX hardware real-time multiprocessing operating system used on the XPS controller assures precise management of the multiple processes with the highest reliability. Multiple TCL programs run in a time-sharing mode with the same priority and will get interrupted only by the servo, or communication tasks.

The advantage of executing application code within the controller over host run code is faster execution and better synchronization, in many cases without any time taken from the communication link. The complete communication link can be reserved for time critical process interaction from or to the process or host controller.

NOTE

It is important to note that the XPS gives communication requests priority over TCL script execution. When using TCL scripts for machine security or other time critical tasks, it is therefore important to limit the frequency of continuous communication requests from a host computer, which includes the XPS website, and to verify the execution speed of repetitive TCL scripts.

3.0 Getting Started

3.1 Unpacking and Handling

It is recommended that the XPS Controller/Driver be unpacked in your lab or work site rather than at the receiving dock. Unpack the system carefully; small parts and cables are included with the equipment. Inspect the box carefully for loose parts before disposing of the packaging. You are urged to save the packaging material in case you need to ship your equipment.

3.2 Inspection for Damage

XPS Controller/Driver has been carefully packaged at the factory to minimize the possibility of damage during shipping. Inspect the box for external signs of damage or mishandling. Inspect the contents for damage. If there is visible damage to the equipment upon receipt, inform the shipping company and Newport Corporation immediately.

WARNING



Do not attempt to operate this equipment if there is evidence of shipping damage or you suspect the unit is damaged. Damaged equipment may present additional personnel hazard. Contact Newport technical support for advice before attempting to plug in and operate damaged equipment.

3.3 Packing List

Included with each XPS-RLD controller are the following items:

- XPS-RLD Start-Up Manual.
- Straight-through Ethernet cable, black, 5 meters.
- Power cord.
- Driver card (installed in controller) on XPS-RLDM version

If there are missing hardware or have questions about the hardware that were received, please contact Newport.

3.4 System Setup

This section guides the user through the proper set-up of the motion control system. If not already done, carefully unpack and visually inspect the controller and stages for any damage. Place all components on a flat and clean surface.

WARNING



Before operating the XPS-RLD controller, please read chapter 1.0 very carefully.

CAUTION



The XPS-RLD controller includes several protections against wiring and configuration errors. However, attempting to operate with wrong connections or parameters may lead to material damage.

**CAUTION**

No cables should be connected to the controller at this point!

3.4.1 Rack Mounting Kit

The XPS-RLD controller is basically intended to be installed on a flat surface such as a table or a cabinet shelf.

A rack mounting kit can be provided separately to properly secure the controller in a standard 19" electronic enclosure. It is composed of two brackets and handles that can be easily attached on the sides of the controller. Both orientations mounting are possible as shown below.

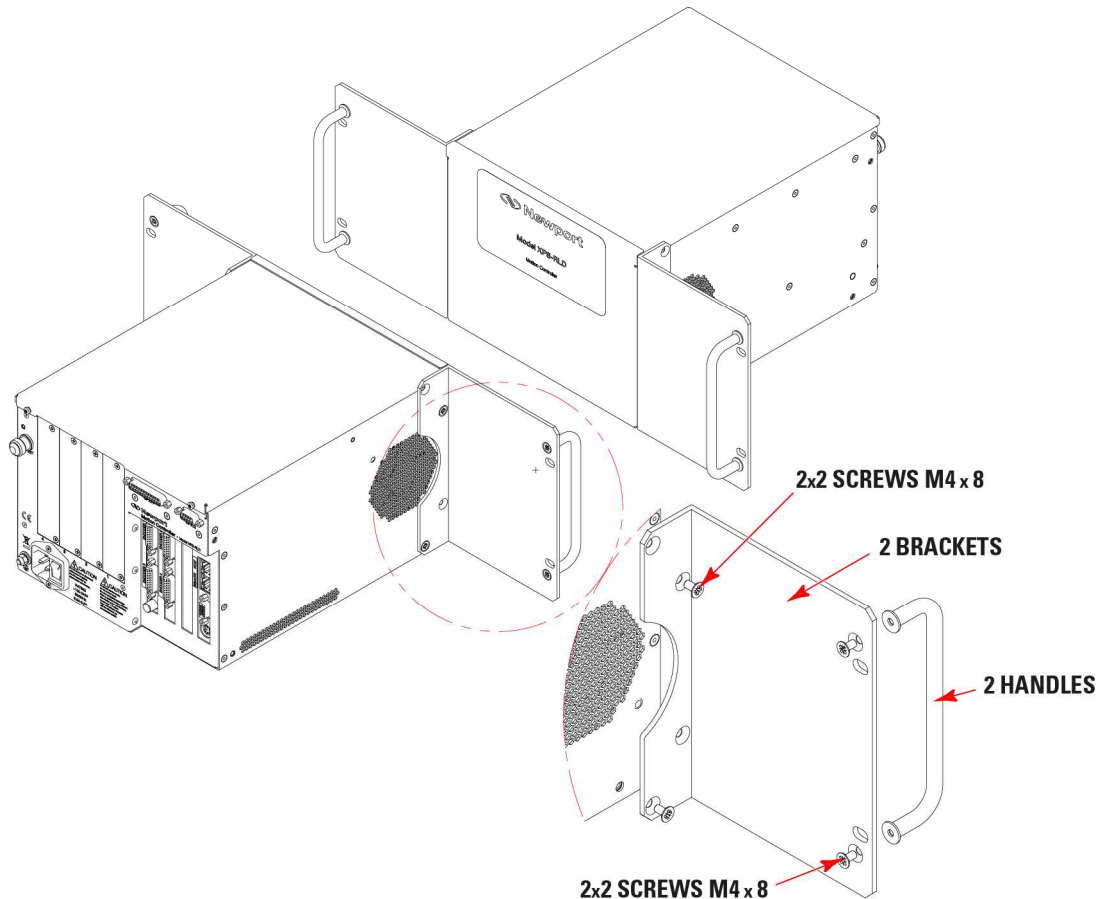

Figure 11: Front rack mounting.

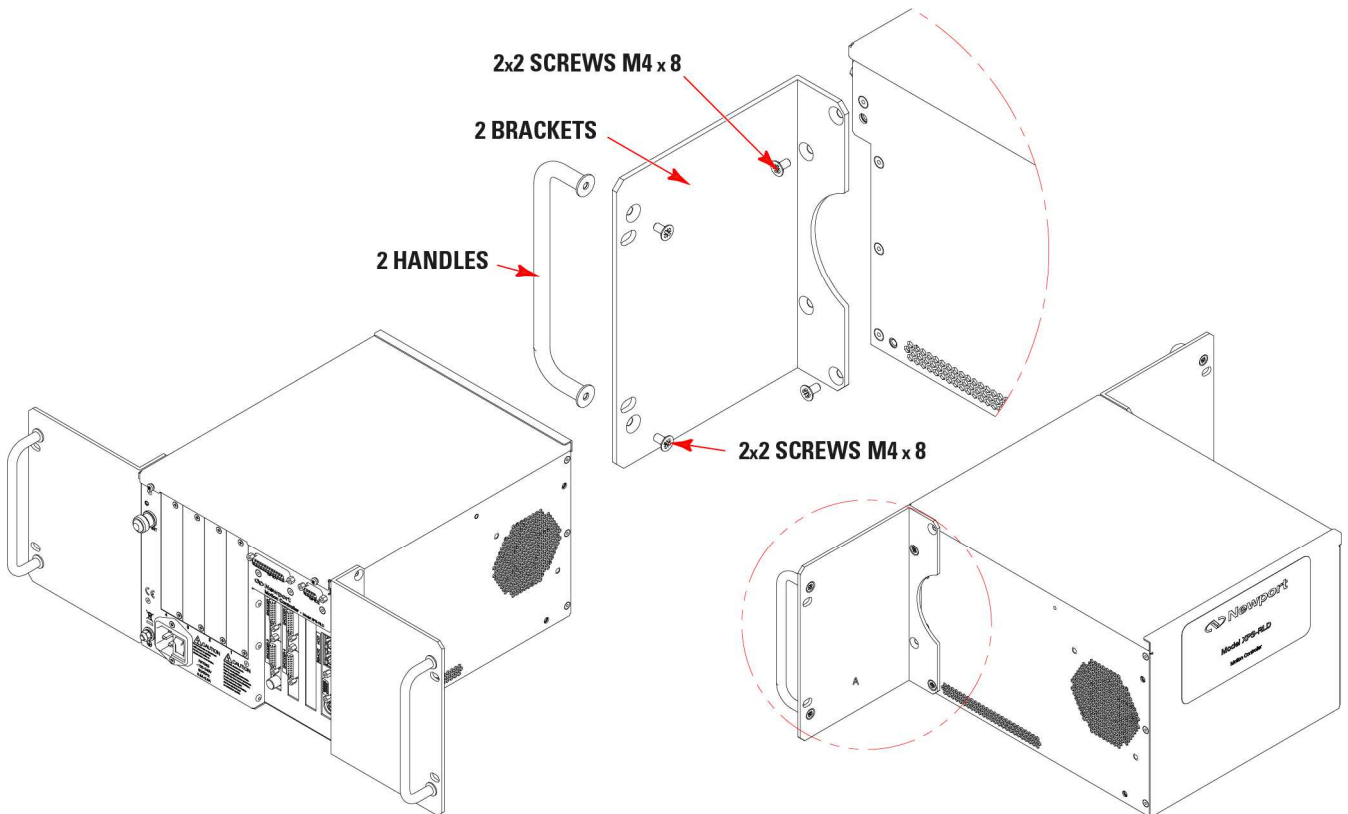

Figure 12: Rear rack mounting.

3.4.2 Installing Driver Cards

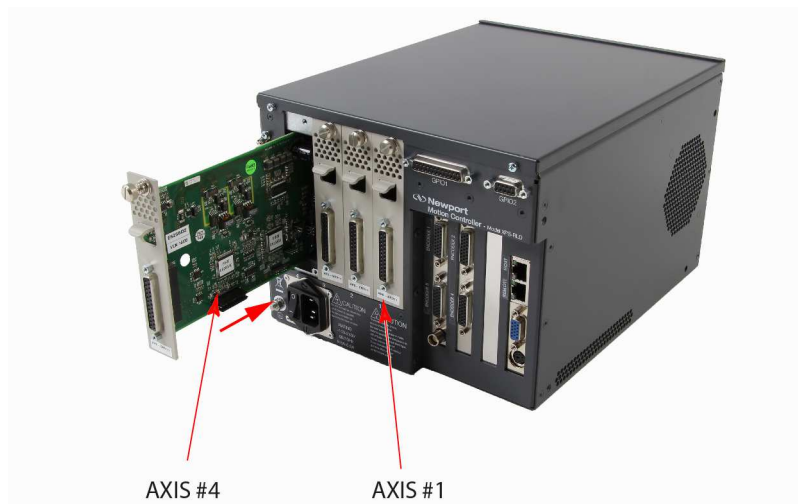

Figure 13: Installing driver cards.

No driver is included except for XPS-RLDM, already fitted with an XPS-DRV02 card. Due to the high power of the XPS-RLD controller, ventilation is very important. To ensure a good level of heat dissipation, the following rules must be followed:

1. It is strictly forbidden to use the XPS controller without the cover properly mounted on the chassis.
2. Driver boards must be inserted from right (driver 1) to left (driver 4) when looking at the rear of the controller.
3. If less than four are used, the remaining slots must be disabled with the appropriate slot covers that were delivered with the controller.

- The surrounding ventilation holes at the sides and back of the XPS unit must be free from obstructions that prevent the free flow of air.

If necessary, proceed as follows:

- Refer to Driver boards specifications in appendix for appropriate driver card choice.
- Remove the necessary slot covers
- Starting from the right, carefully insert the driver cards and tighten their securing bolt.

CAUTION



Carefully read the labels on the driver cards and make sure the specifications (motor type, voltage, current, etc.) match those of the motion devices you intend to connect. Severe damage could occur if a stage is connected to the wrong driver card.

3.4.3 Connecting to the Main

- If desired, a second protective earth line can optionally be connected to the M5 ground stud at the rear of the controller (tighten the nut at 0.5 N.m).
- The line current must be limited by a 16A fuse or circuit breaker and it must be protected according applicable standards.
- The controller must be installed in such a way that power switch and power connector are accessible by the user.
- Plug the AC line cord supplied with the XPS into the AC power receptacle on the rear panel.
- Plug the AC line cord into the wall-outlet.

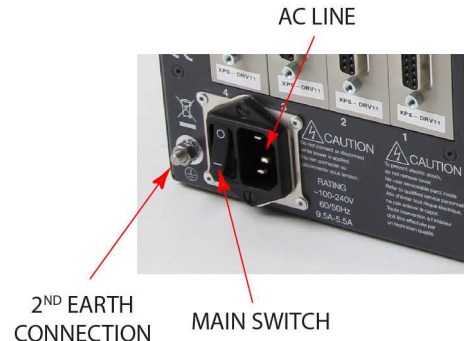

Figure 14: Earth & AC line connections.



WARNING

The AC mainline must include a protective earth.

NOTE

Power Input: 100–240 V, 60/50 Hz, 9.5–5.5 A

3.4.4 Power ON

- Turn the Main Power Switch to ON (located on the Rear Panel).
- There is an initial beep after power on and a second beep when the controller has finished booting. If the controller boots properly, the second beep is happy-sounding, otherwise the sad-sounding beep is emitted. The time between the first and the second beeps is approx. 30 seconds.
- There is also an Inhibit switch with a BNC connector in the rear of the XPS. The Inhibit switch is directly linked by hardware to cut off motor power supply.

3.5 Connecting to the XPS

XPS supports 10/100/1000 Mbps Ethernet networking and can be accessed through:

1. Direct connection PC-to-XPS.

The Ethernet plugs “REMOTE” or “HOST” can either be used.

The plug “REMOTE” has a fixed IP address (192.168.254.254). The DHCP server active on this plug will automatically configure the connected computer to make it ready for communication with the XPS controller.

The “HOST” plug has an adjustable IP address (192.168.0.254 upon delivery). This plug requires the connected computer to be set to a compatible IP address value.

2. Network connection.

The Ethernet plug identified “HOST” must be used to connect the XPS controller to a Network. Before connection, the controller IP setting must be set by the Network administrator.

The following cable is provided with the motion controller.

This standard Ethernet straight through black cable can be used when either connecting the device directly to a PC or to a standard network hub or switch.

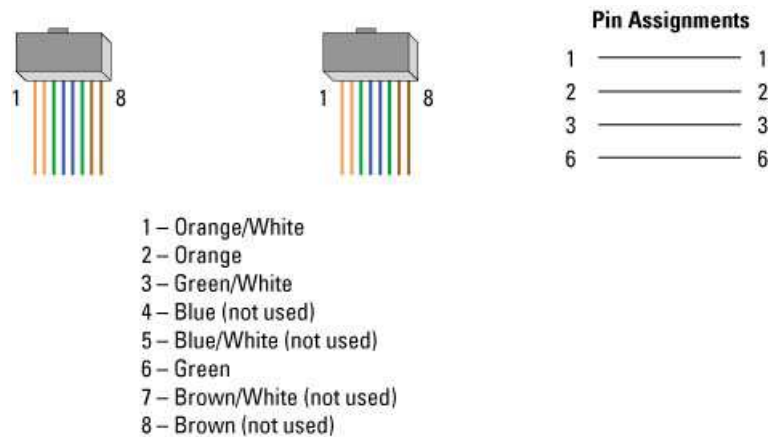

Figure 15: Straight through cables.

3.5.1 Direct Connection to the XPS Controller

For a direct connection between a PC and the XPS controller you need to use the Ethernet cable and either the REMOTE or the HOST connector at the back of the XPS.

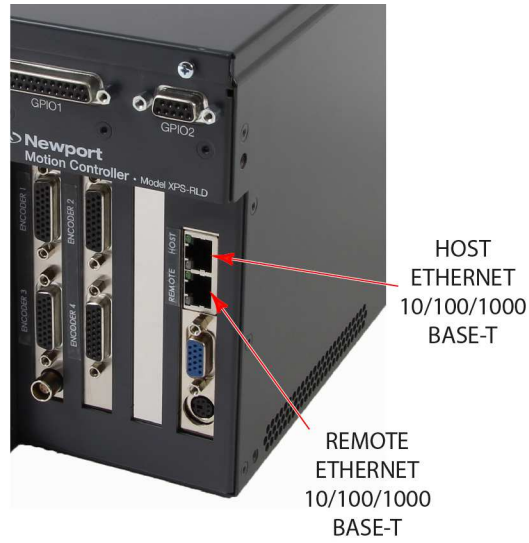
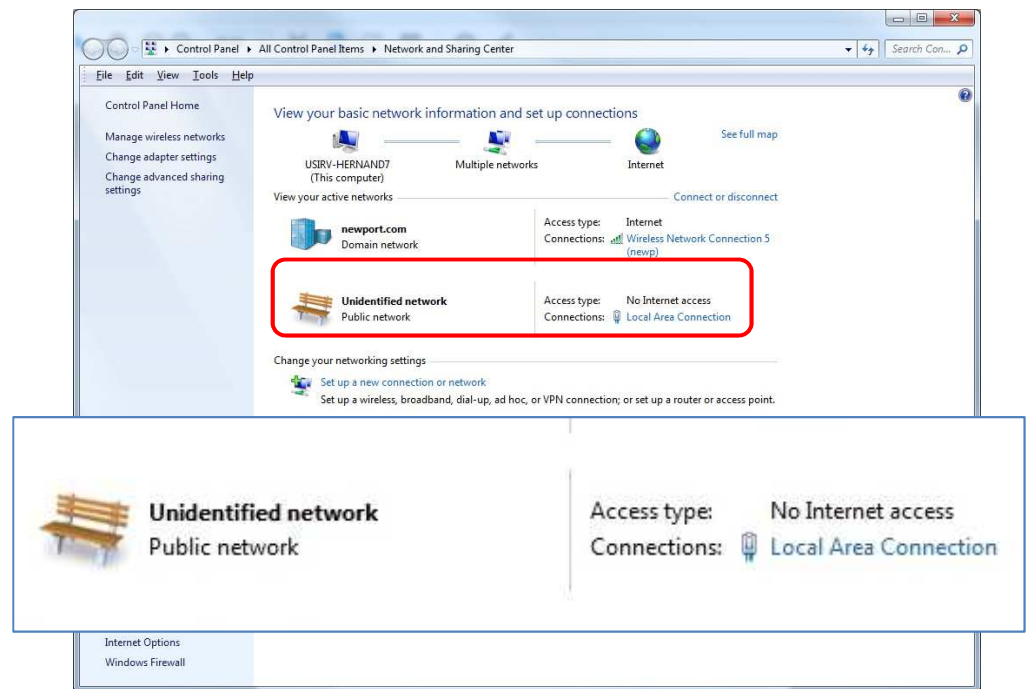

Figure 16: Direct connection to the XPS using an Ethernet cable.

REMOTE Connection:

- After connecting the REMOTE connector on the back of the XPS to the PC, an Unidentified network will appear in your active networks found under Control Panel > Network and Sharing Center.



The REMOTE plug has a DHCP server which automatically assigns an IP address on the PC's Ethernet card.

Use the following procedure to ensure the Local Area Connection is set to Obtain an IP address automatically.

This procedure is for the Windows 7 operating system (almost similar process for Windows 8):

- Start Button > Control Panel > Network and Sharing Center => Change adapter settings.
- Right Click on Local Area Connection Icon and select Properties.

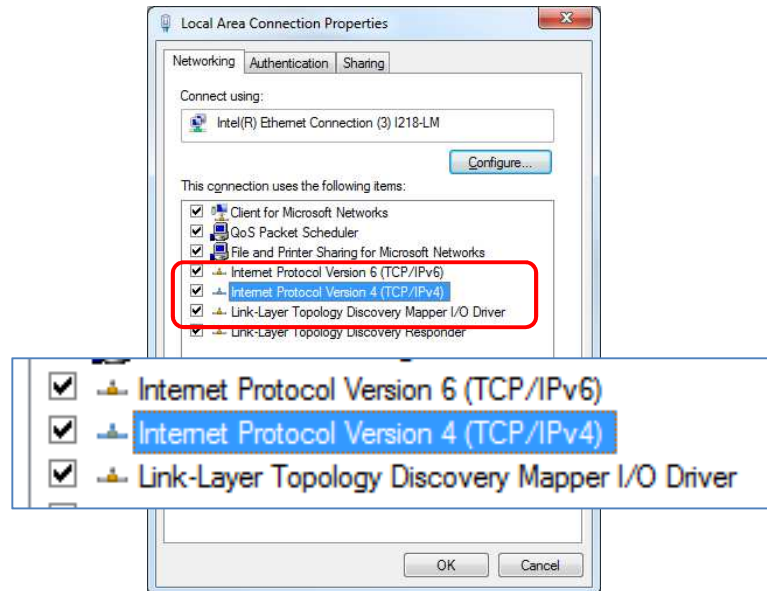

- Highlight Internet Protocol Version 4 (TCP/IPv4) and click on Properties.

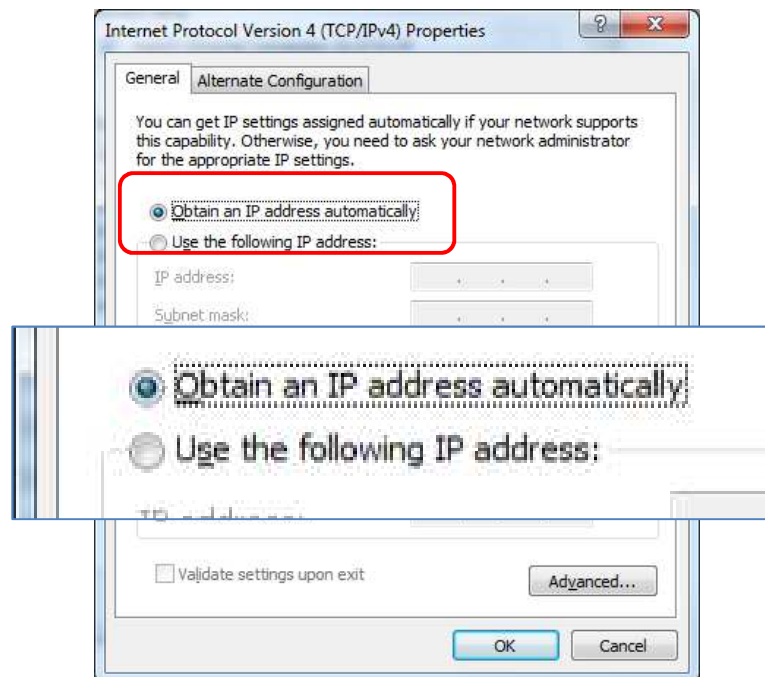

- Verify Obtain an IP address automatically is selected and click "OK".

HOST Connection:

- Proceed the same way but select "Use the following IP address" in the previous screenshot.
- Type "IP address: 192.168.0.100" and "Subnet mask: 255.255.255.0" for example (assuming the HOST IP address is still at the original value 192.168.0.254) and click "OK".

Procedure for connecting to the controller:

- Open an Internet Browser and connect to <http://192.168.0.254> in case using HOST connector or connect to <http://192.168.254.254> in case using REMOTE connector.

Login:

Name: **Administrator**

Password: **Administrator** (Please see the picture below).

Role: **Administrator**

NOTE

Please note that the login text is case sensitive.

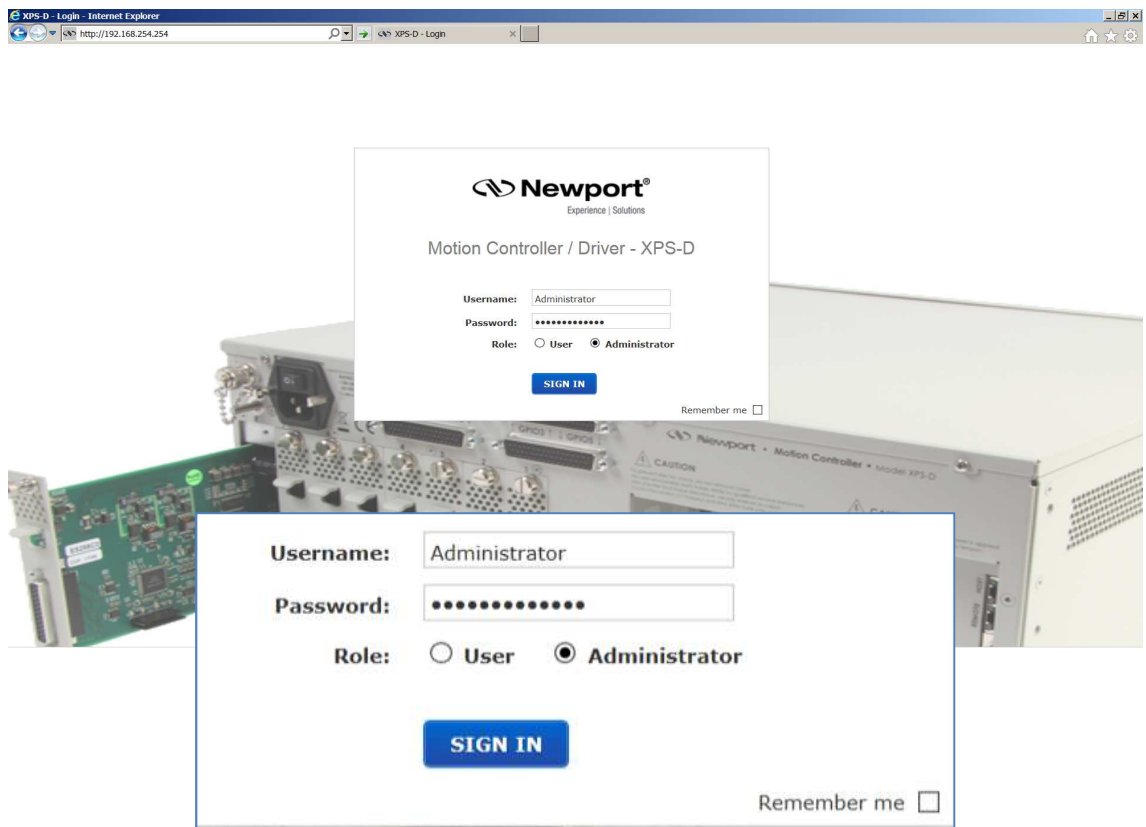

Once logged in, the XPS has established a direct connection to the local computer.

The user interface is the same as the XPS-D controller and is fully described in XPS-D User Interface manual.

If you don't want to connect the XPS controller through a Corporate Network you may skip to section 3.6: "Connecting the Stages".

NOTE

If you want to change the HOST IP address of the XPS controller, follow the explanation in the next section. It is necessary to keep using the Ethernet cable to connect the XPS controller directly to the PC.

3.5.2 Connecting the XPS to a Corporate Network Using Static IP Configuration

Once you are logged in using the previously described steps with a direct connection, you can change the IP configuration of the controller in order to connect the XPS over a Network.

- Get to **Controller** → **IP management** web page
- Select Static IP configuration as shown below:

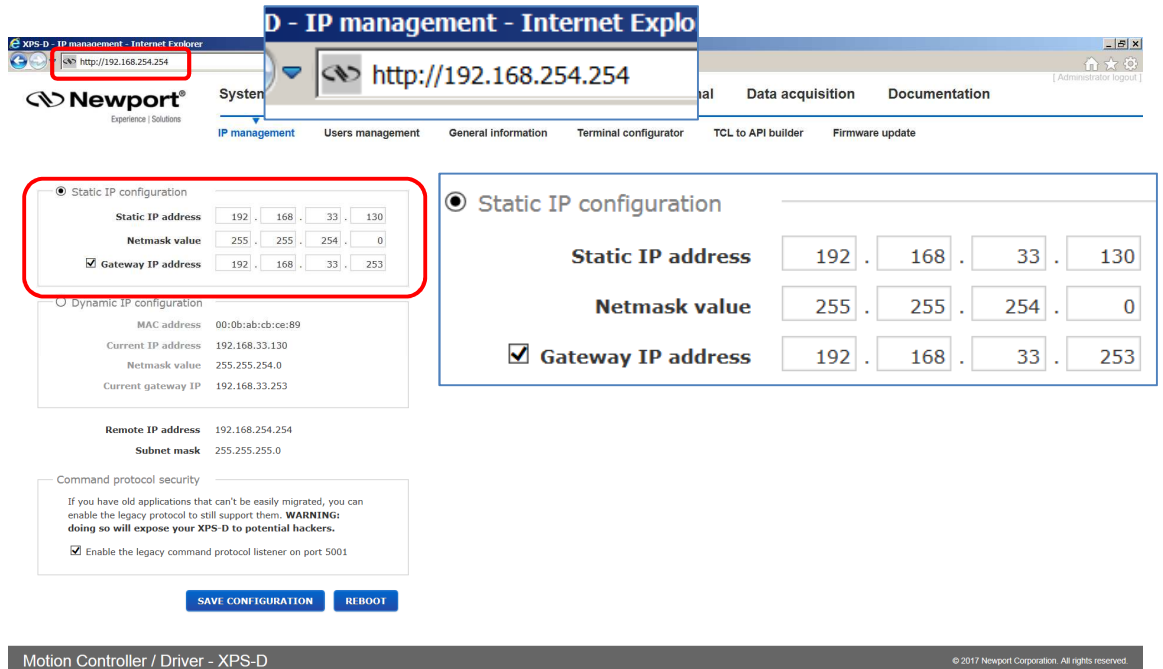

Motion Controller / Driver - XPS-D

© 2017 Newport Corporation. All rights reserved.



CAUTION

The Static IP address, the Netmask value and the Gateway IP address must be provided by your Network Administrator to avoid network conflicts!

- Once you have these addresses, you can input them in the IP configuration window as shown above. The above shown addresses are only examples.

NOTE

To avoid conflict with the REMOTE Ethernet plug, the IP address must be different from 192.168.254.

NOTE

For the majority of Networks, the setting above for the Netmask value will work. However, for larger networks (200 computers or more), the Netmask value address must be verified with the IT department. In most cases and for larger networks, the Netmask value is set to 255.255.0.0.

- Once the appropriate addresses for the Static IP configuration are set, click on "SAVE CONFIGURATION" and the following screen appears:

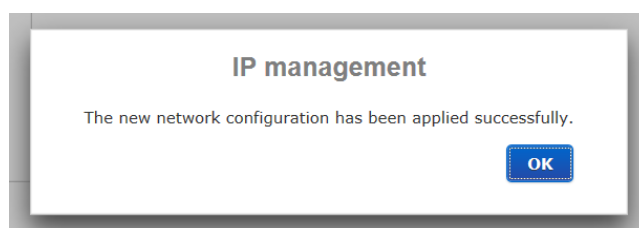

- Click "OK" and reboot the controller by clicking REBOOT.

A pop-up windows appears showing the “REBOOT IN PROGRESS”. When the boot sequence is complete, the user is redirected to the login page. The time to reboot is about 50 seconds.

- Connect an Ethernet cable to the HOST connector of the XPS controller and to your network.
- Remove the REMOTE cable and, if needed, configure your PC back to its original Ethernet configuration, you have saved before modification.
- Open your internet browser and use the Static IP address.

If you don't want to connect directly to the Corporate Network using the Dynamic IP Configuration, skip to section 3.6: “Connecting the Stages”.

3.5.3 Configuring the XPS for Connection to a Corporate Network Using Dynamic IP Configuration

It is recommended to ask your IT department to configure the XPS to your network to avoid any issue with your network policies and rules.

- Connect to REMOTE plug of the XPS as described in section 3.5.1: “Direct Connection to the XPS Controller”
- Connect an Ethernet cable to the HOST connector of the XPS controller and to your network.
- Get to **Controller** → **IP management** web page
- Select dynamic IP as shown below:

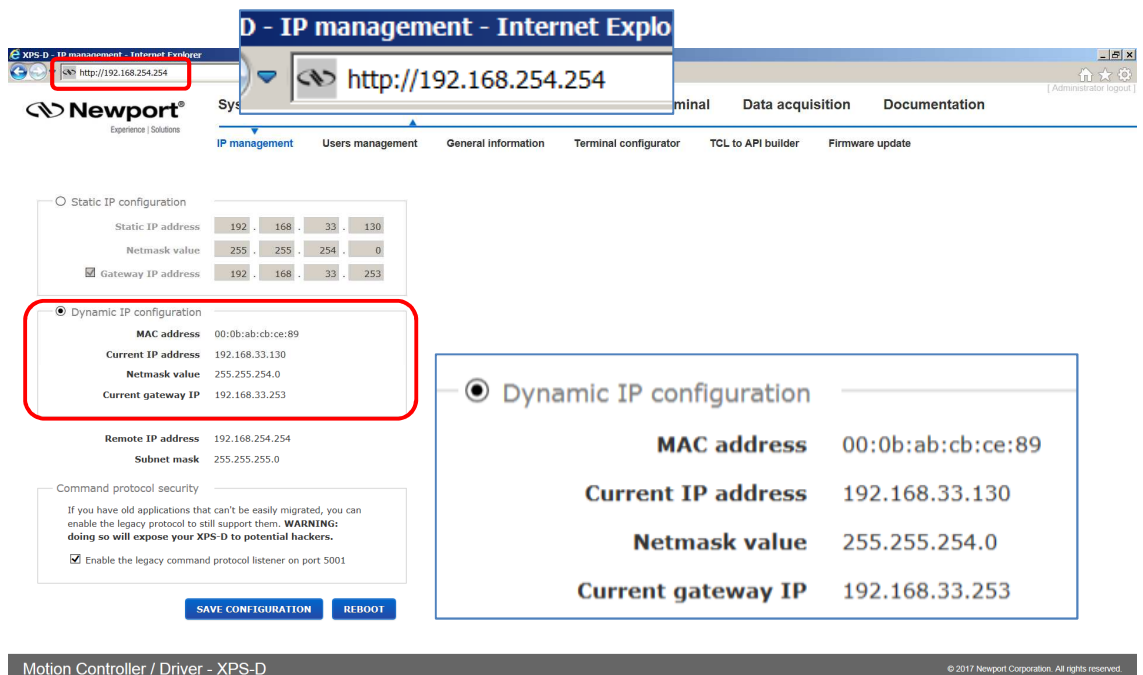

- Click the “SAVE CONFIGURATION” button and the following screen appears:

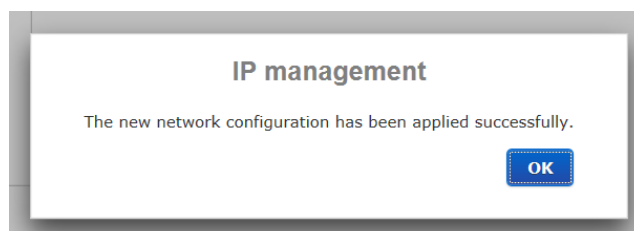

- Go to the TERMINAL window, click on the Reboot function, then press the OK button:

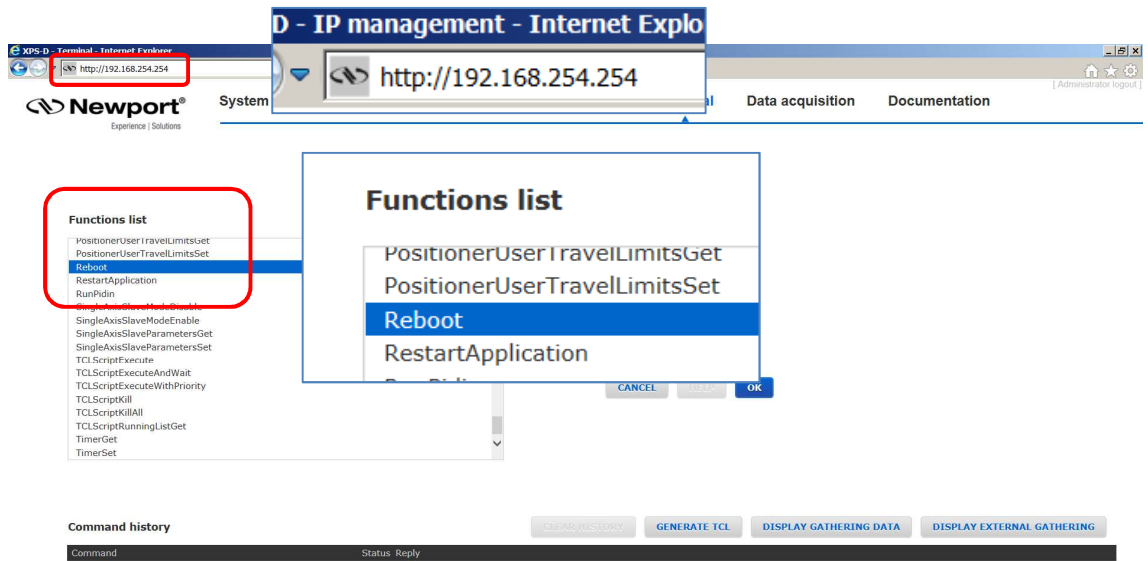

Motion Controller / Driver - XPS-D © 2017 Newport Corporation. All rights reserved.

- Wait for controller to reboot, open the internet browser and connect again to REMOTE

You can see the dynamic IP address in **Controller** → **General**.

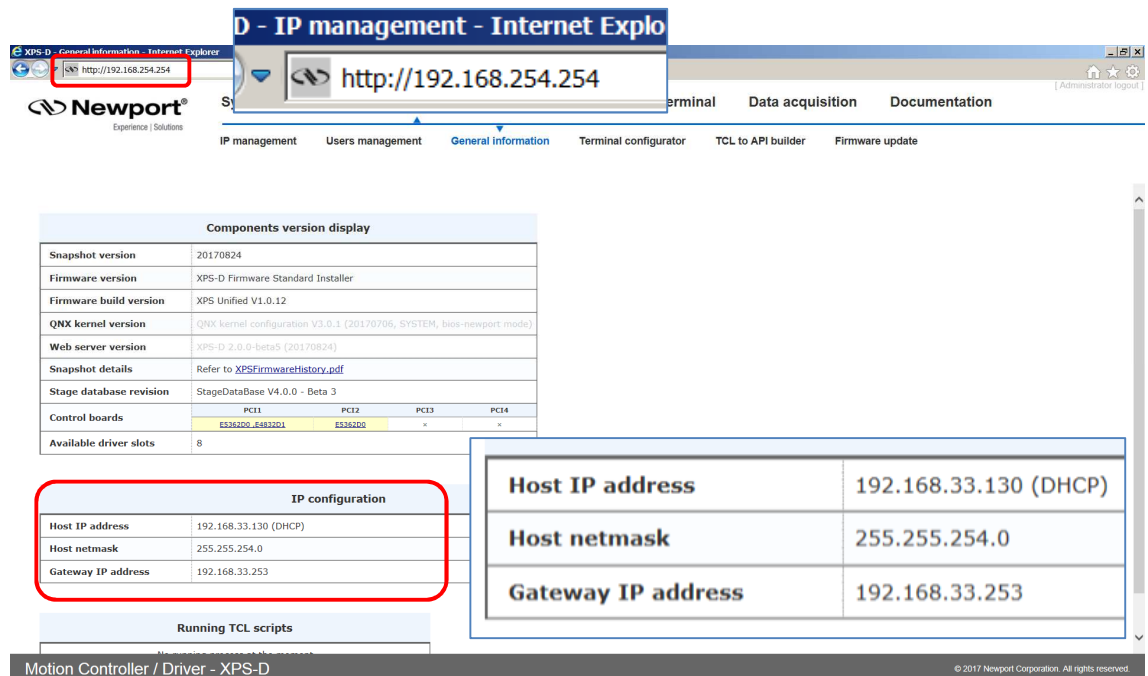

The IP address delivered by your DHCP is displayed above.

- In case the XPS cannot negotiate an IP address from the DHCP the displayed address will be 0.0.0.0. In that case contact your IT department.
- Remove the REMOTE cable and, if needed, configure your PC back to its original Ethernet configuration, you have saved before modification.

- Make sure that the Ethernet cable is connected to the HOST connector of the XPS controller and to your network.
- Open your internet browser and use the dynamic IP address.

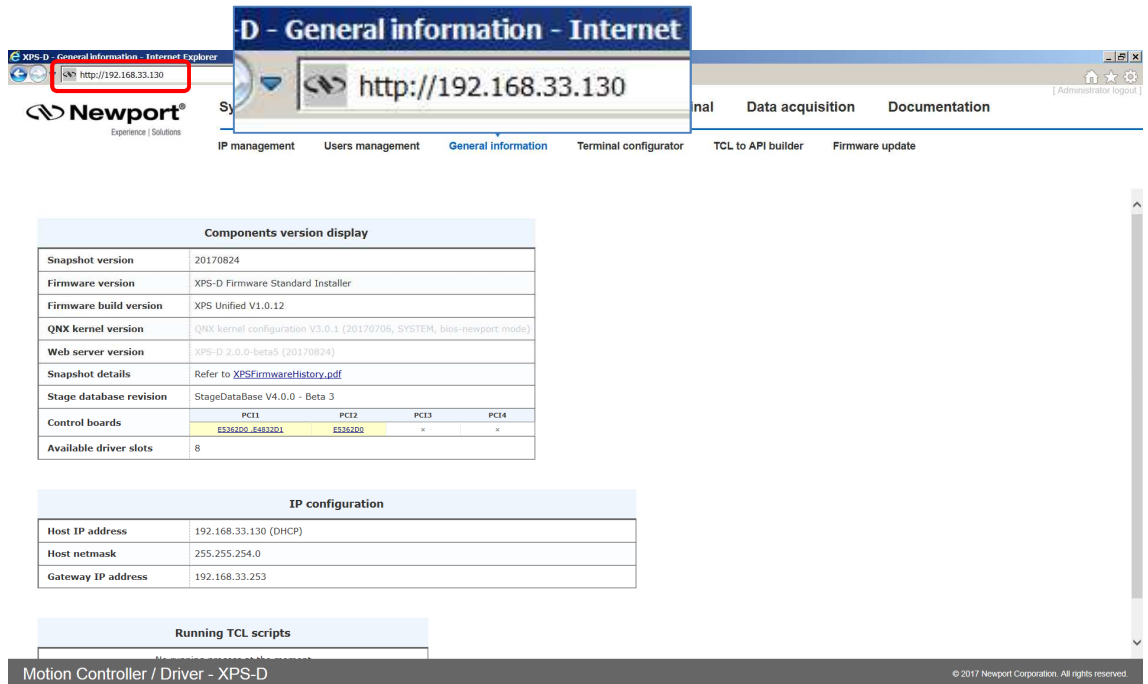

- Check with your IT department that the lease time set at the DHCP is longer than the time you plan to leave the XPS switched off otherwise you will lose your dynamic address and will need to connect to the REMOTE to know the new assigned one by the DHCP.

NOTE

Do not use Dynamic IP configuration if your DHCP server uses Windows NT 4.0.

3.5.4 Recovering a Lost IP Configuration

If you want to recover a lost IP configuration, you need to connect the PC directly to the REMOTE connector at the back of the XPS with the Ethernet cable.

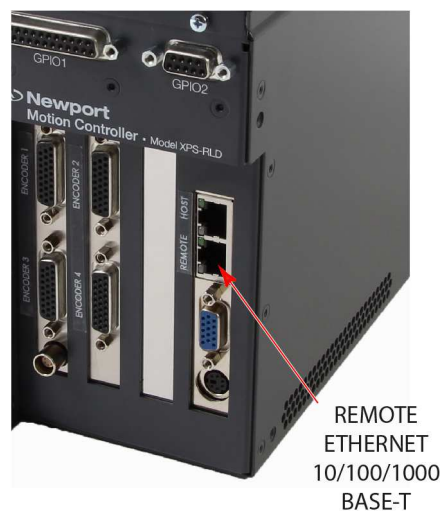

Figure 17: Direct connection to the XPS-RLD using an Ethernet cable and the REMOTE connector.

First, the IP address on the PC’s Ethernet card must be set to Obtain IP Address Automatically.

- Open Internet Browser and connect to **http://192.168.254.254**

Login:

Name: **Administrator**

Password: **Administrator** (Please see the picture below).

Rights: **Administrator**

NOTE

Please note that the login text is case sensitive.

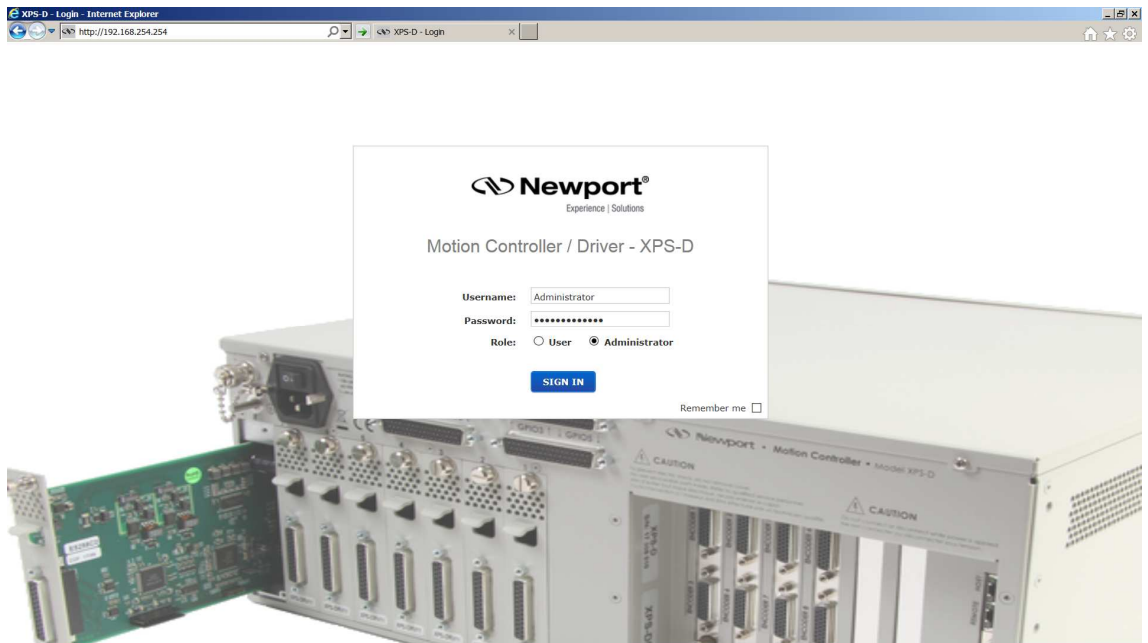

- Once you are logged in, you can change the IP configuration by following the steps described in section 3.5.2 or 3.5.3 depending on your configuration.

NOTE

If you want to reset the IP address to the default factory setting, follow the section 3.5.2: “Connecting the XPS to a Corporate Network Using Static IP Configuration” to set the IP address back to 192.168.0.254.

3.5.5 Testing your XPS-PC Connection and Communication

To check if the XPS communicates with to the host computer, send a ping message from the computer to the XPS. This is done through the Windows menu: Start->Run->, then type: ping + IP address of the XPS. See the example below for the IP address 192.168.254.254:

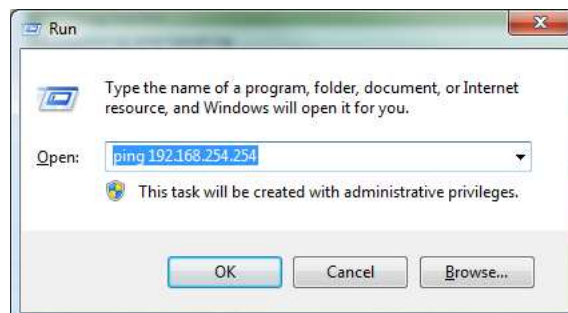

If the XPS is connected and communicates properly, it replies in the terminal window that appears after clicking on the OK button:

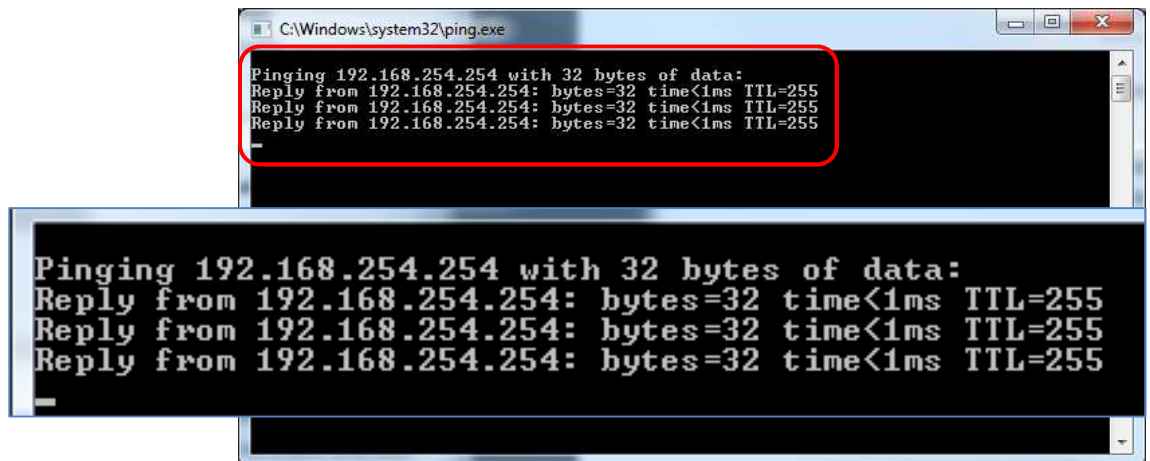

The image shows a screenshot of a Windows command prompt window titled "C:\Windows\system32\ping.exe". The window displays the output of a ping command to the IP address 192.168.254.254. The output is as follows:

```
Pinging 192.168.254.254 with 32 bytes of data:  
Reply from 192.168.254.254: bytes=32 time<1ms TTL=255  
Reply from 192.168.254.254: bytes=32 time<1ms TTL=255  
Reply from 192.168.254.254: bytes=32 time<1ms TTL=255  
-
```

A red rectangular box highlights the first three lines of the output, which indicate successful replies from the target IP address.

If the XPS controller is not communicating, the window displays that the time delay of the request is exceeded. Ensure that the correct cable and IP addresses are set properly.

3.6 Connecting the Stages



CAUTION

Never connect/disconnect stages while the XPS controller is powered on.



CAUTION

Mount the stage(s) on a flat, stable surface before connecting to the XPS controller.

- Power off the controller.
- Carefully connect the supplied cables to the stage and to the appropriate axis connector at the rear of the controller. Secure both connections with the locking thumbscrews.
- When using stages with an analog encoder interface, a separate encoder cable must be connected to the corresponding axis connector of the control board labeled “Encoder 1” to “Encoder 4”.

Please note that the XPS controller will not detect cross-connection errors between the motor of one stage and the encoder of another stage. Make sure that motor, encoder and other cables are plugged to the appropriate axis driver card and encoder connectors.

All Newport ESP-compatible stages are electrically and physically compatible with the XPS controller. ESP-compatible stages are visually identified with a blue “ESP Compatible” sticker on the stage. If an ESP-compatible motion system was purchased, all necessary hardware to connect the stage with the XPS controller is included. The stage connects to the XPS via a shielded custom cable that carries all the power and control signals (encoder, limits, and home signals). The cable is terminated with a standard 25-pin D-Sub connector.

Dummy Stages

“Dummy stages” can be used to simulate a stage. This feature allows users to configure and test the system’s behavior without having real stages or driver card connected.

To configure your system with a number of dummy stages use Manual configuration. For more information about Manual configuration see XPS-D Configuration Manual.

Dummy stage configuration file can be found in the StageDataBase.txt file with name [DUMMY@DUMMY_STAGE@NO_DRIVER].

3.7 Configuring the Controller

Refer to XPS-D Configuration Manual.

3.8 Using the Controller

Refer to XPS-D User Interface Manual for more information about controller user interface.

See also XPS-D Features Manual for explanations about controller functions and operation.

3.9 Documentation

Under the webpage Documentation, users can open and download XPS manuals and drivers.

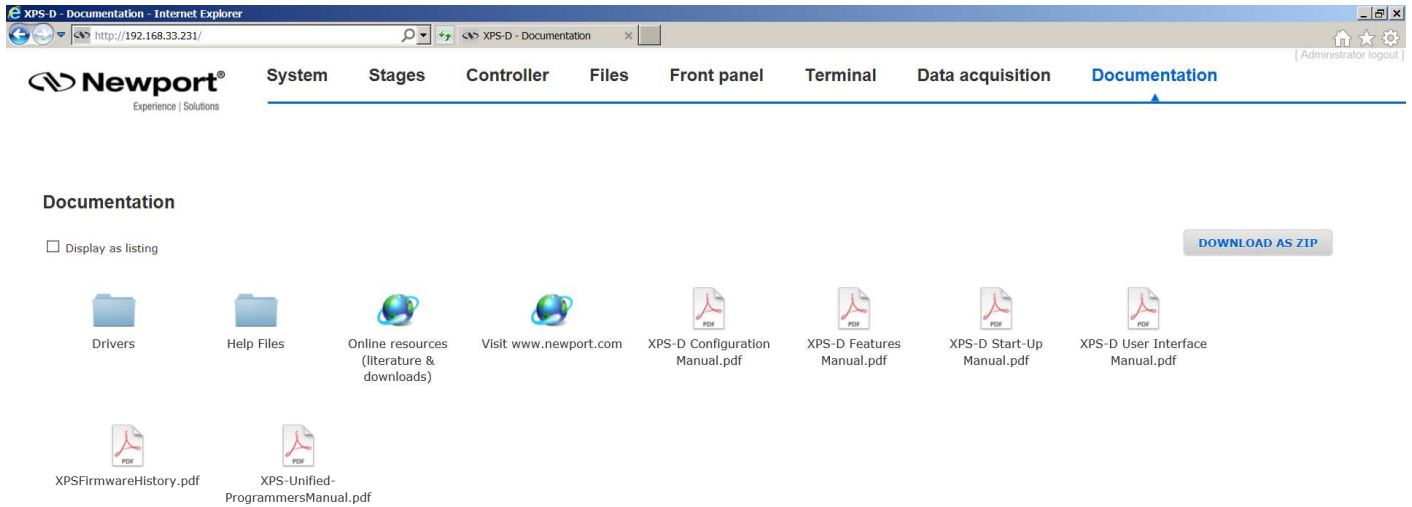

3.10 SFTP (Secured File Transfer Protocol) Connection

All usual file management can be done from the controller website interface. Nevertheless, SFTP connection is another option to manage file transfers from an external application.

Example, using Filezilla for secured FTP transfer:

- Run Filezilla and open Site Manager
- Create a new site, select SFTP Protocol
- Enter IP address, login and password

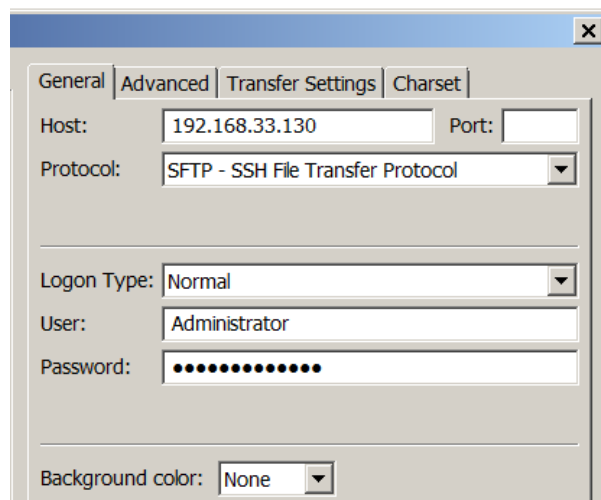

- Click Connect

The folders of the XPS controller are displayed (see below). Browse through the different folders and transfer data from or to your host PC.

When connected to the controller with FTP as Administrator, the user has access to configuration files. The Administrator home directory contains folders: Config, Firmware, UserOptionalModules and Webfiles.

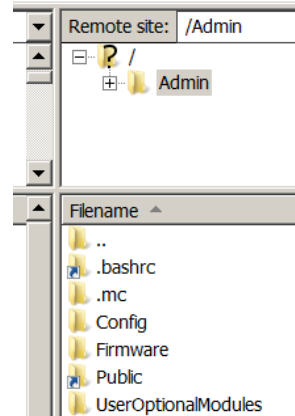

When connected to the controller with FTP as an ordinary user such as Anonymous, the user has access to Public files. The ordinary user the home directory contains folders: Gathering, Log, Scripts, and Trajectories.

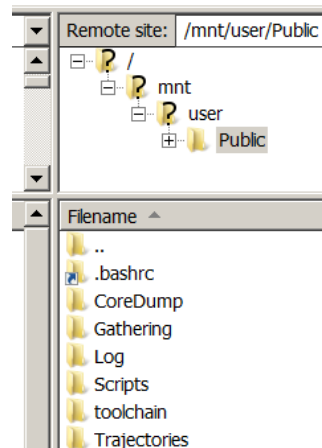

You can also use “puTTY psftp.exe” for secured FTP transfer.

3.11 Samba Microsoft SMB/CIFS Networking Protocol

A secured protocol (Samba) has been implemented and also allows the controller Public folder (this folder only) to be attached and detached to the computer as a network drive.

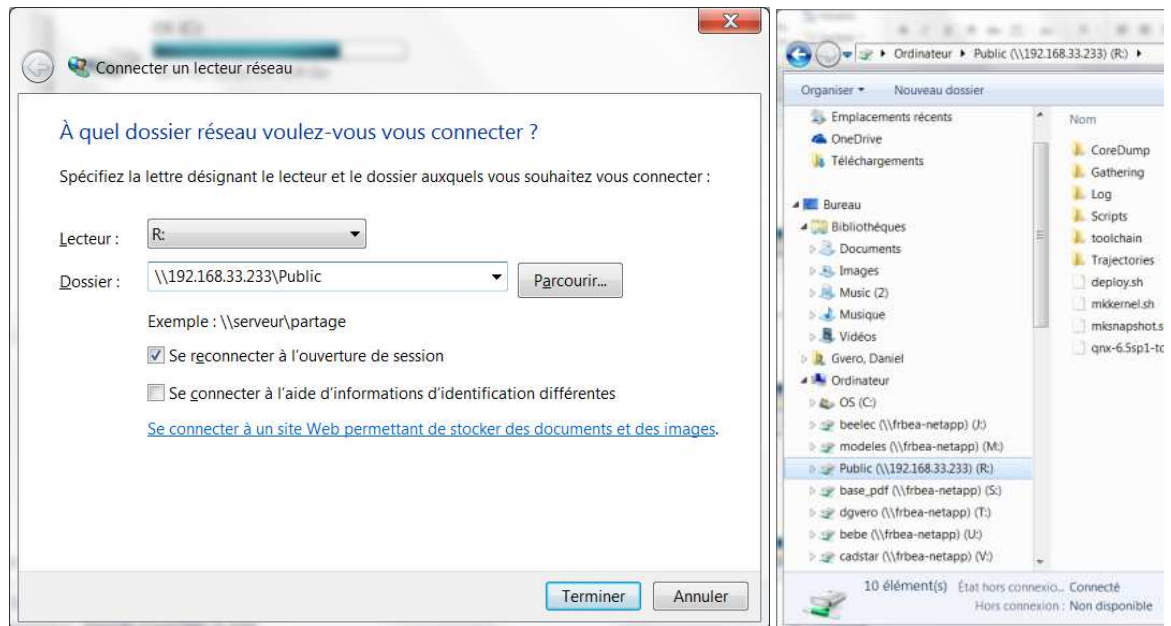

3.12 System Shut-Down

To shut down the system entirely, perform the following procedure:

- Wait for the stage(s) to complete their moves and come to a stop.
- Turn off the power using the power switch located above the power cord at the back of the controller.

4.0 Maintenance and Service

4.1 Enclosure Cleaning

The XPS-RLD Controller/Driver should only be cleaned with a sufficient amount of soapy water solution. Do not use an acetone or alcohol solution; this will damage the finish of the enclosure.

4.2 Obtaining Service

The XPS-RLD Controller/Driver contains no user serviceable parts. To obtain information regarding factory service, contact Newport Corporation or your Newport representative and be ready with the following information:

- Instrument model number (on front panel) and original order number.
- Instrument serial number (on rear panel).
- Description of the problem.

If the XPS is to be returned to Newport Corporation, a Return Number will be issued, which should be referenced in the shipping documents.

Complete a copy of the Service Form found at the end of this Manual and include it with your shipment.

4.3 Troubleshooting

For troubleshooting, the user can query different error and status information from the controller. The XPS controller provides the Positioner Error, the Positioner Hardware Status, the Positioner Driver Status, the Group Status, and also a general system error.

If there is an error during command execution, the controller will return an error code. The command `ErrorStringGet` can be used to retrieve the description corresponding to the error code.

The following function commands are used to retrieve Positioner Error and Positioner Hardware Status:

- `PositionerErrorGet`: Returns an error code.
- `PositionerErrorStringGet`: Returns the description of the error code.
- `PositionerHardwareStatusGet`: Returns the status code.
- `PositionerHardwareStatusStringGet`: Returns the description corresponding to the status code.

In a fault condition, it is also very important to know the current status of the group and the cause of the transition from the previous group status to the current group state. The following functions can be used to retrieve the Group Status:

- `GroupStatusGet`: Returns the group status code.
- `GroupStatusStringGet`: Returns the description corresponding to the group status code.

NOTE

Refer to the XPS Unified Programmer's Manual for a complete list of status and error codes. Also refer to XPS-D User Interface Manual for troubleshooting the XPS controller with the help of its web utilities.



Appendix

5.0 Appendix A: Hardware

5.1 Controller

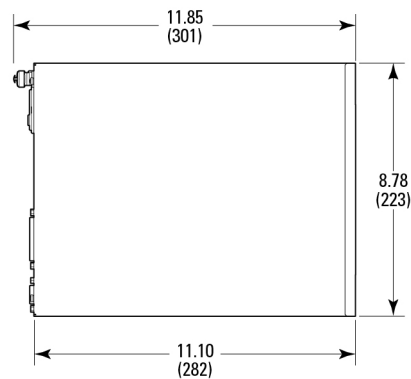
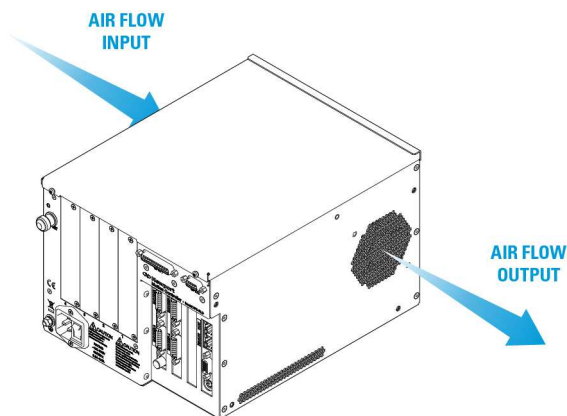

MODEL SHOWN: XPS-RLD4
DIMENSIONS IN INCHES (AND MILLIMETERS)

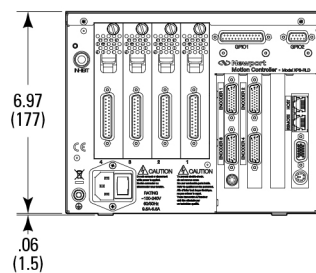

BOTH SIDES: 4 HOLES M4 THD,
USABLE DEPTH <.24 (6)

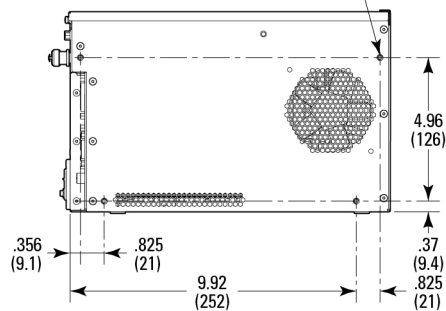

Weight: 5.5 kg (12.1 lb) with 4 driver boards
Air flow: 45 CFM

5.3 Controller with Rack Mounting Kit

5.3.1 Front Rack Mounting

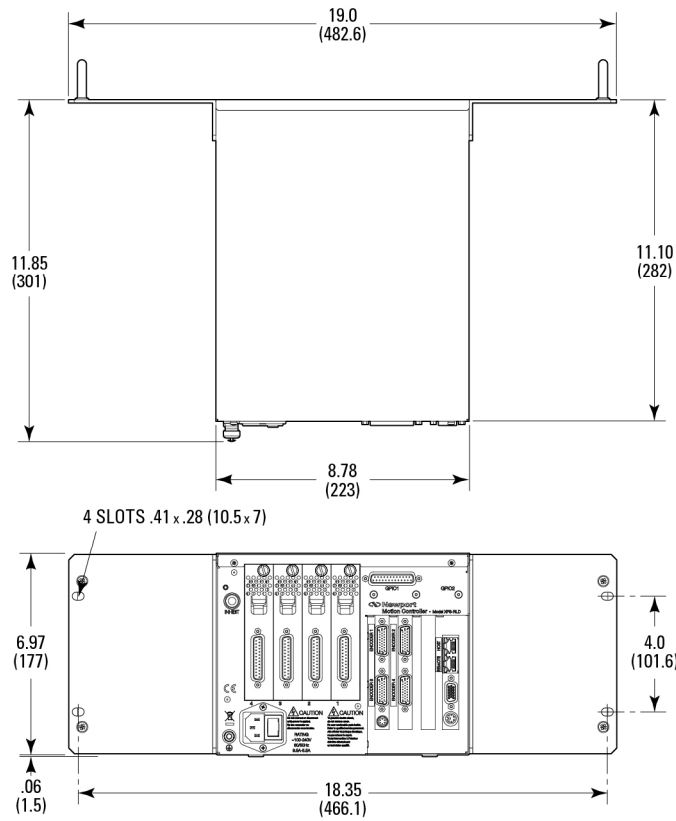

5.3.2 Rear Rack Mounting

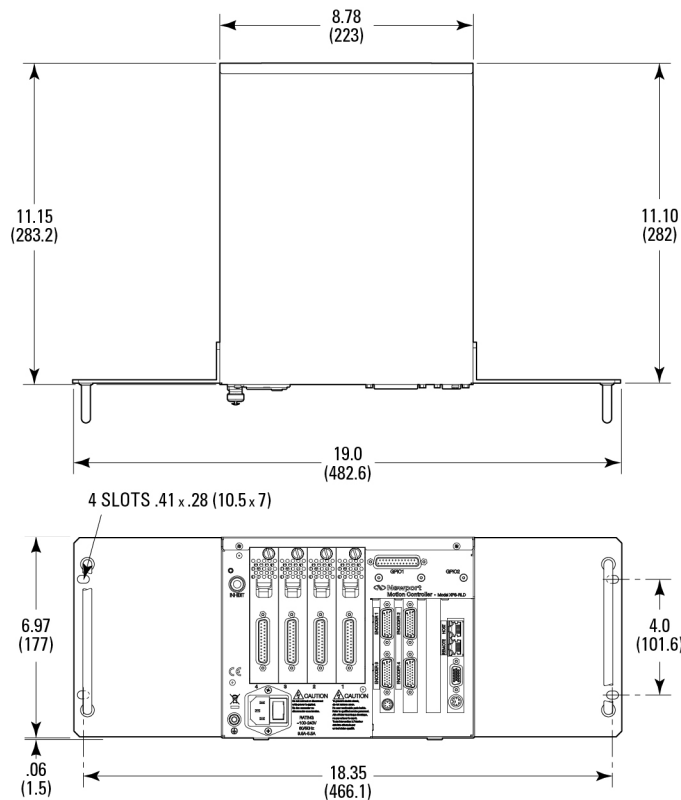

5.4 Rear Panel Connectors

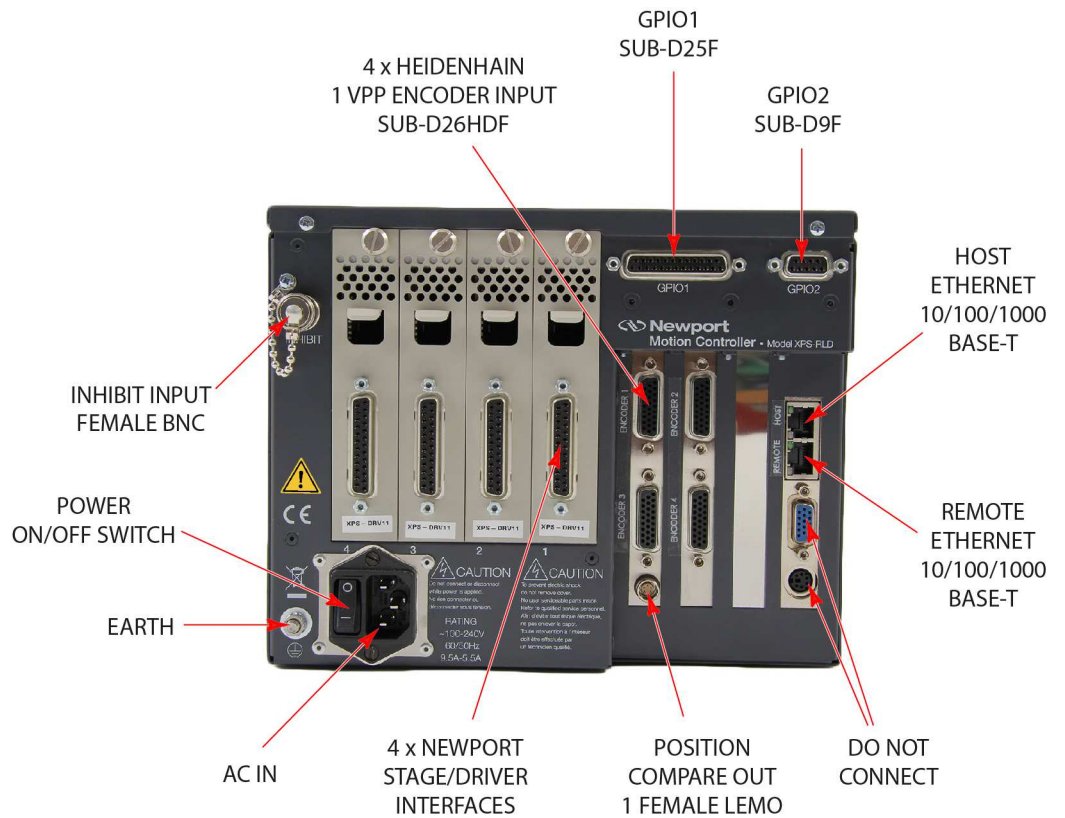

Figure 18: Rear Panel.

6.0 Appendix B: General I/O Description

This chapter briefly describes all XPS signal types and details each of the XPS connector interfaces.

6.1 Digital I/O (GPIO1)

All digital I/Os are TTL compatible:

- All digital I/Os are not isolated but are referenced to electrical ground (GND).
- Input levels must be between 0 V and +5 V.
- All digital inputs are identical, except for GPIO1.DI_7 and GPIO1.DI_8 (synchronization inputs) that have no internal pull-up
- Output levels should be at least +5 V (up to 30 V absolute maximum rating with open collector outputs).
- Outputs must be pulled up to the user's external power supply (+5 V to +24 V). This external power supply must be referenced to the XPS ground (GND).

All digital I/Os are refreshed asynchronously on user requests. Therefore, digital inputs or outputs have no refresh rate.

Typical delay is 100 μ s due to the clock cycle and priorities made to other functions.

All digital inputs are in negative logic and have internal +5 V pull up resistors, except for the synchronization inputs, GPIO1.DI_7 and GPIO1.DI_8, that have no internal pull-up resistors.

6.1.1 Digital Inputs

Parameter	Symbol	Min.	Max.	Units
Low-Level Input Voltage	V_{IL}	0	0.8	V
High-Level Input Voltage	V_{IH}	1.6	5	V
Input Current LOW	I_{IL}	–	-2.5	mA
Input Current HIGH	I_{IH}	–	0.4	mA

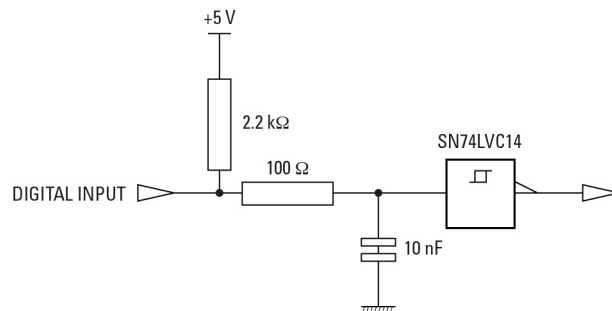
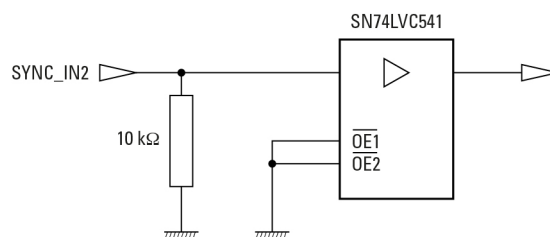

Figure 19: Digital TTL input.

GPIO1 inputs can be accessed via the `GPIODigitalGet(GPIO1.DI, ...)` function.

GPIO1 Synchronization Inputs



Synchronization Input 1: GPIO or External Trigger Input.

Synchronization Input 2: GPIO or Slave Controller Clock Input.

6.1.2 Digital Outputs

Parameter	Symbol	Min.	Max.	Units
Low-Level Output Voltage	V_{OL}	0	1	V
High-Level Output Voltage	V_{OH}	2.4	30	V
Input Current LOW	I_{OL}	-	-40	mA
Input Current HIGH	I_{OH}	-	0.2	mA

All digital outputs are in negative logic (NPN open collector, 74LS06 TTL type circuit) and have no internal pull up to permit levels above +5 V.

These outputs are not limited Power Source.

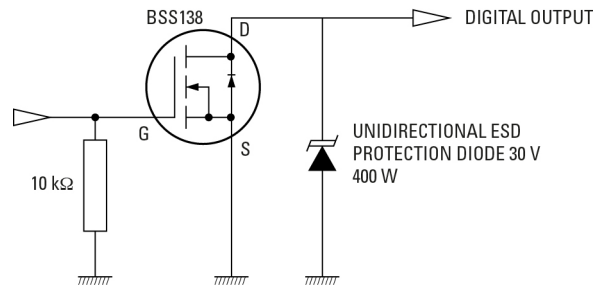
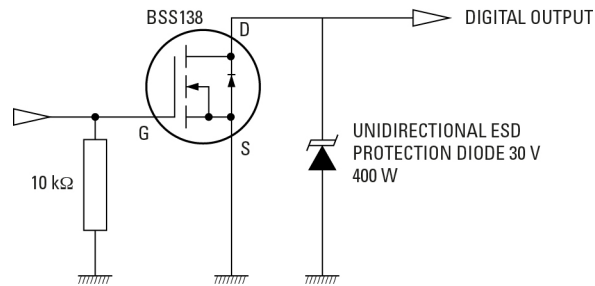

Figure 20: Open collector digital output.

GPIO1 outputs can be accessed via the GPIODigitalSet(GPIO1.DO, ...) function.

GPIO1 Synchronization Outputs



Synchronization Output 1: GPIO or Trajectory trigger output pulses.

Synchronization Output 2: GPIO or Master Controller Clock output.

6.1.3 GPIO1 Connector

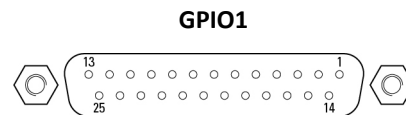

NOTE

Mating connector: Male SUB-D25 with UNC4/40 lockers.

GPIO1			
Pin #	Function	Pin #	Function
1	GND	14	TTL Input 1
2	TTL Input 2	15	GND
3	TTL Input 3	16	TTL Input 4
4	GND	17	TTL Input 5
5	TTL Input 6	18	GND
6	Synch. Input 1 (TTL Input 7)	18	Synch. Input 2 (TTL Input 8)
7	GND	20	O.D. Output 1
8	O.D. Output 2	21	GND
9	O.D. Output 3	22	O.D. Output 4
10	GND	23	O.D. Output 5
11	In window (O.D. Output 6)	24	GND
12	Synch. Output 1 (O.D. Output 7)	25	Synch. output 2 (O.D. Output 8)
13	+5 V		

Figure 21: GPIO1 digital I/O connector.

Synchronization Input 1: GPIO or External Trigger Input.

Synchronization Input 2: GPIO or Slave Controller Clock Input.

In window: GPIO or Trajectory “in window” signal

Synchronization Output 1: GPIO or Trajectory trigger output pulses.

Synchronization Output 2: GPIO or Master Controller Clock output.

6.2 Analog I/O (GPIO2)

6.2.1 Analog Inputs

The 2 analog inputs have a range of ± 10 V, 12 Bit resolution, and a 200 kHz 1 st order low pass filter.

In all cases, the analog input values must be within the ± 10 V range. The analog input impedance is typically 30 k Ω . The maximum input current is ± 350 μ A.

1 LSB = 20 V/4096 \approx 4.88 mV

ADC offset and gain error are compensated.

Analog inputs can be accessed via the GPIOAnalogGet(GPIO2.ADCn,...) function.

6.2.2 Analog Outputs

The 2 analog outputs have a range of ± 10 V and 12 Bit resolution. DAC offset and gain error are compensated. The DAC settling time is 5 μ s and the outputs have a 200 kHz 1 st order low pass filter.

Analog outputs are voltage outputs (output current less than 1 mA), so to use them properly, they must be connected to an impedance higher than 10 k Ω .

1 LSB = 20 V/4096 \approx 4.88 mV.

These outputs are not limited Power Source.

Analog outputs can be accessed via the GPIOAnalogSet(GPIO2.DACn,...) function.

6.2.3 GPIO2 Connector

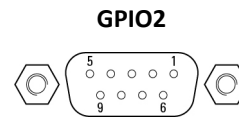

NOTE

Mating connector: Male SUB-D9 with UNC4/40 lockers.

GPIO2			
Pin #	Function	Pin #	Function
1	GND	6	Analog Input 1
2	GND	7	Analog Input 2
3	GND	8	Analog Output 1
4	GND	9	Analog Output 2
5	GND		

Figure 22: GPIO2 analog I/O connector.

6.3 Digital Encoder Inputs (Driver Boards & DRV00P)

All digital encoder inputs are RS-422 standard compliant:

- All digital encoder signals are not isolated but are referenced to the electrical ground (GND).
- Encoder signals must be differential pairs (using 26LS31 or MC3487 line driver type circuits). Encoder inputs have a terminating impedance of 120 Ω.
- Inputs are always routed on differential pairs. For a high level of signal integrity, we recommend using shielded twisted pairs of wires for each differential signal.
- Encoder power supply is +5 V @ 250 mA maximum (referenced to the electrical ground) and is sourced directly by the driver boards. The +5 V power supply is low noise (approximately 20 mVpp), fuse protected up to 500 mA/plug, and supplies 5.13 V without load.

6.4 Digital Servitudes (Driver Boards, DRV00P & Analog Encoders Connectors)

All servitude inputs are TTL compatible:

- All servitude inputs are not isolated but are referenced to the electrical ground (GND).
- Input levels must be between 0 V and +5 V.

All servitude inputs are refreshed synchronously with the XPS servo rate.

All servitude inputs are identical.

All servitude inputs expect normally closed sensors referenced to ground (input is activated if the sensor is open) and have internal 2.2 kΩ pull up resistors to the +5 V.

6.5 Analog Encoder Inputs (Analog Encoder Connectors)

6.5.1 Analog Encoder Connector

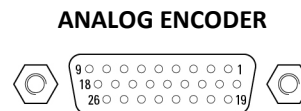

NOTE

Mating connector: Male SUB-D26HD with UNC4/40 lockers.

ENCODER			
Pin #	Function	Pin #	Function
1	+5 V	14	Home or Limit+
2&3	N.C.	15	/Sine
4	Cosine	16	N.C.
5	Limit or Limit-	17	Index Pulse /I
6	Sine	18	N.C.
7	GND	19	+5V
8	Index Pulse I	20 to 24	N.C.
9 to 12	N.C.	25	GND
13	/Cosine	26	GND

Figure 23: Analog encoder connector.

This connector is used to receive sine/cosine encoder signals.

The sinusoidal position signals, sine and cosine, must be phase-shifted by 90° and have signal levels of approximately 1 VPP. Each of these two signals is composed of an analog sinusoidal signal and its complement entering in a differential amplifier.

Sine, Cosine and Index signals

Analog Sine, Analog /Sine, Analog Cosine and Analog /Cosine inputs are the sine and cosine information from the encoder glass scale. Levels for these individual signals are typically 1 VPP differential signals (maximum 1.2 VPP) ADC Full Scale, 2.4 MHz maximum input frequency and interpolation at x65536.

Analog Index and Analog /Index inputs are used to receive Index information from the encoder glass scale.

Encoder Power Supply

The +5 V provided on Encoder plugs is a dedicated power supply with the following characteristics:

- Low noise (approximately 20 mVpp)
- Fuse protected (500 mA/plug)
- 5.13 V without load

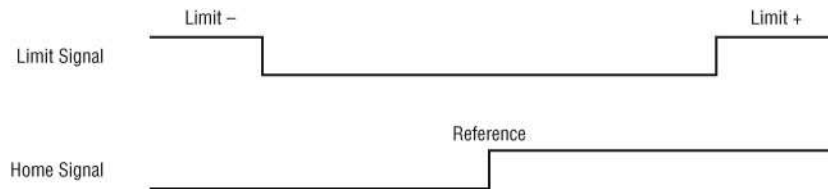

Figure 24: Limit and Home TTL input signals.

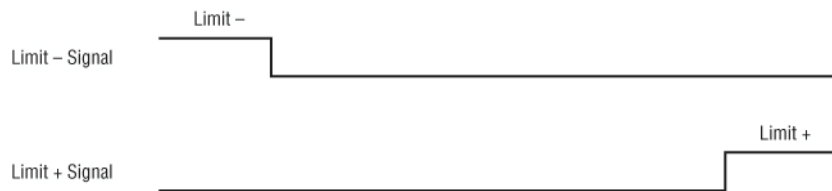

Figure 25: Limit - and Limit + TTL input signals.

7.0 Appendix C: Power Inhibit Connector

7.1 Description

Inhibit in XPS is a female BNC Connector intended for wiring a remote STOP ALL switch. (If not used, the BNC plug must remain in place to allow operation)



The BNC pin is connected to XPS inhibit and BNC outer shell is connected to GND. For normal operation of the XPS, the Inhibit must be connected to GND in order to work. When inhibit is open the drivers power supply is switched OFF

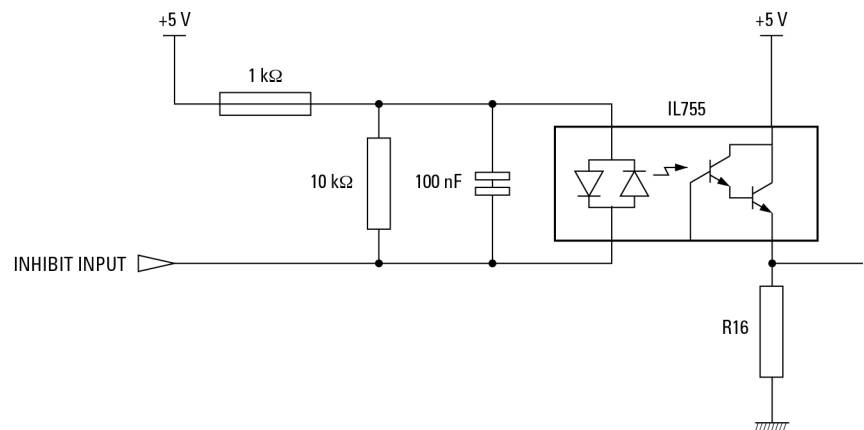
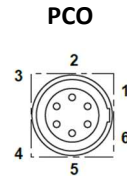

Figure 26: Inhibition connector.

8.0 Appendix D: PCO Connector

8.1 Description

This chapter briefly describes the PCO (Position Compare Output) feature of the XPS. There are two versions of PCO for XPS controllers, namely Basic PCO and Extended PCO. The XPS-RLD controller features a Basic PCO. It differs from the Extended PCO in that XY or XYZ error mapping can not be used to compensate position and interpolation factor is lower.



NOTE

Mating connector: LEMO FGG0B306CLAD52 (or 42).

PCO	
Pin #	Function
1	+5 V (fused: max 63 mA)
2	Axis 1 PCO Pulse/QuadA
3	Axis 1 PCO Enable/QuadB
4	Axis 2 PCO Pulse/QuadA
5	Axis 2 PCO Enable/QuadB
6	GND

Figure 27: PCO (Position Compare Output) connector.

	Time Spaced Pulses	Distance Spaced Pulses	AquadB
Minimum pulse width	35 ns	35 ns	–
Minimum pulse frequency	0.05 Hz		
Maximum pulse frequency	20 MHz	1.6 MHz (5 MHz for less than 4096 pulses)	
Interpolation	–	X256	AquadB encoder: x4 AnalogInterpolated encoder: x4, x256, x4096
Accuracy	5 ns	5 ns	5 ns
Position Window capability	YES	-	YES

Figure 28: Extended position compare output.

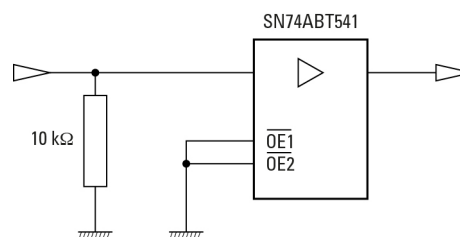

Figure 29: Output high level = 3 V minimum.

There is one PCO connector for Axis 1 and Axis 2 (PCO is not available for Axis 3 and 4). The signals provided on this plug depend on the configuration of the output triggers, see **XPS-D Features Manual** for more details (Basic PCO).

The state of the enable signal is active when the stage is inside the programmed position compare window. The pulse configuration can enable the pulse polarity.

The duration of the pulse is 2 μ s by default and can be modified using the function **PositionerPositionComparePulseParametersSet()**. Possible values for PCOPulseWidth are: 35 ns to 327.68 μ s (5 ns resolution). Successive trigger pulses should have a minimum time lag of 625 ns (200 ns for less than 4096 pulses).

The PCO signal is driven by SN74ABT541 line driver.

9.0 Appendix E: Motor Driver Cards

9.1 Universal digital DC, Stepper and Direct Drive Motor Driver XPS-DRV11

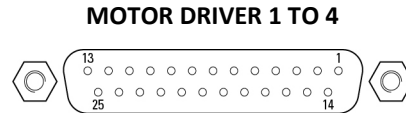

NOTE

Mating connector: Male SUB-D25 with UNC4/40 lockers.

MOTOR DRIVER					
Pin #	DC Motor	Stepper Motor	Brushless / Direct Drive	Pin #	All Motors
1	N.C.	+ Phase 1	Phase U	13	Origin
2	N.C.	+ Phase 1	Phase U	14	GND
3	N.C.	- Phase 1	N.C.	15	Index
4	N.C.	- Phase 1	N.C.	16	GND
5	Motor+	+ Phase 2	Phase V	17	+ Travel Limit
6	Motor+	+ Phase 2	Phase V	18	- Travel Limit
7	Motor-	- Phase 2	Phase W	19	Encoder A
8	Motor-	- Phase 2	Phase W	20	Encoder B
9	N.C.	N.C.	Thermistor	21	+5V
10	N.C.	N.C.	Hall U	22	GND
11	N.C.	N.C.	Hall V	23	Encoder /A
12	N.C.	N.C.	Hall W	24	Encoder /B
				25	/Index

Figure 30: XPS-DRV11 motor driver connectors.

- Motor +** This output must be connected to the positive lead of the DC motor. The voltage seen at this pin is pulse-width modulated with maximum amplitude of 47 VDC.
- Motor -** This output must be connected to the negative lead of the DC motor. The voltage seen at this pin is pulse-width modulated with maximum amplitude of 47 VDC.
- + Phase 1** This output must be connected to Winding A+ lead of a two-phase stepper motor. The voltage seen at this pin is pulse-width modulated with maximum amplitude of 47 VDC.
- Phase 1** This output must be connected to Winding A- lead of a two-phase stepper motor. The voltage seen at this pin is pulse-width modulated with maximum amplitude of 47 VDC.
- + Phase 2** This output must be connected to Winding B+ lead of a two-phase stepper motor. The voltage seen at this pin is pulse-width modulated with maximum amplitude of 47 VDC.
- Phase 2** This output must be connected to Winding B- lead of a two-phase stepper motor. The voltage seen at this pin is pulse-width modulated with maximum amplitude of 47 VDC.
- Phase U, V, W** These outputs must be connected to the 3 windings of a 3-phase brushless or direct drive motor. The voltage seen at this pin is pulse-width modulated with maximum amplitude of 47 VDC.
- Hall U, V, W** These inputs are pulled-up to +5 V with 2.43 kΩ resistor and represent the Hall sensor signals used for the initial brushless motor initialization.

Thermistor	This input is connected to a 1 k Ω resistor to 5V. It can be used with up to 9k Ω thermistor.
+ Travel limit	This input is pulled-up to +5 V with a 2.2 k Ω resistor by the controller and represents the stage positive direction hardware travel limit.
- Travel limit	This input is pulled-up to +5 V with a 2.2 k Ω resistor by the controller and represents the stage negative direction hardware travel limit.
Encoder A & /A	These A and /A inputs are differential inputs. Signals are compliant with RS422 electrical standard and are received with a MC3486 differential line receiver. A resistor of 120 Ω adapts the input impedance. The A and /A encoder signals originate from the stage position feedback circuitry and are used for position tracking.
Encoder B and /B	These B and /B inputs are differential inputs. Signals are compliant with RS-422 electrical standard and are received with a MC3486 differential line receiver. A resistor of 120 Ω adapts the input impedance. The B and /B encoder signals originate from the stage position feedback circuitry and are used for position tracking.
Index & /Index	These Index and /Index inputs are differential inputs. Signals are compliant with RS422 electrical standard and are received with a MC3486 differential line receiver. A resistor of 120 Ω adapts the input impedance. The Index and /Index signals originate from the stage and are used for homing the stage to a repeatable location.
GND	Ground reference.
Origin	This input is pulled-up to +5 V with a 2.2 k Ω resistor by the controller. The Origin signal originates from the stage and is used for homing the stage to a repeatable location.
+5 V (0.25A max.)	+5 VDC supply is available from the driver. This supply is provided for stage home, index, travel limit, and encoder feedback circuitry.

9.2 Piezoelectric Motor Driver XPS-DRVP1

NOTE

Please directly refer to XPS-DRVP1 User's Manual.

9.3 DC and Stepper Motor Driver XPS-DRV01

MOTOR DRIVER 1 TO 4

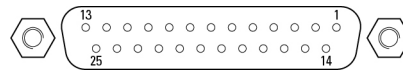

NOTE

Mating connector: Male SUB-D25 with UNC4/40 lockers.

MOTOR DRIVER					
Pin #	DC Motor	Stepper Motor	Pin #	DC Motor	Stepper Motor
1	Tachometer+	Phase 1	14	Shield GND	Shield GND
2	Tachometer+	Phase 1	15	Index	Index
3	Tachometer-	Phase 2	16	Limit GND	Limit GND
4	Tachometer-	Phase 2	17	+Travel Limit	+Travel Limit
5	Motor+	Phase 3	18	- Travel Limit	- Travel Limit
6	Motor+	Phase 3	19	Encoder A	Encoder A
7	Motor-	Phase 4	20	Encoder B	Encoder B
8	Motor-	Phase 4	21	+5 V	+5 V
9	Brake+	Common 3 & 4	22	Encoder GND	Encoder GND
10	N.C.	N.C.	23	Encoder /A	Encoder /A
11	Brake-	Common 1 & 2	24	Encoder /B	Encoder /B
12	N.C.	N.C.	25	/Index	/Index
13	Origin	Origin			

Figure 31: XPS-DRV01 motor driver connectors.

- Motor +** This output must be connected to the positive lead of the DC motor. The voltage seen at this pin is pulse-width modulated with maximum amplitude of 48 V DC.
- Motor -** This output must be connected to the negative lead of the DC motor. The voltage seen at this pin is pulse-width modulated with maximum amplitude of 48 V DC.
- Ph1** This output must be connected to Winding A+ lead of a two-phase stepper motor. The voltage seen at this pin is pulse-width modulated with maximum amplitude of 48 V DC.
- Ph2** This output must be connected to Winding A- lead of a two-phase stepper motor. The voltage seen at this pin is pulse-width modulated with maximum amplitude of 48 V DC.
- Ph3** This output must be connected to Winding B+ lead of a two-phase stepper motor. The voltage seen at this pin is pulse-width modulated with maximum amplitude of 48 V DC.
- Ph4** This output must be connected to Winding B- lead of a two-phase stepper motor. The voltage seen at this pin is pulse-width modulated with maximum amplitude of 48 V DC.
- Common 3&4** This output must be connected to the center tab of Winding B of a two-phase stepper motor. The voltage seen at this pin is pulse-width modulated with maximum amplitude of 48 V DC.
- Common 1&2** This output must be connected to the center tab of Winding A of a two-phase stepper motor. The voltage seen at this pin is pulse-width modulated with maximum amplitude of 48 V DC.
- + Travel limit** This input is pulled-up to +5 V with a 2.2 kΩ resistor by the controller and represents the stage positive direction hardware travel limit.
- Travel limit** This input is pulled-up to +5 V with a 2.2 kΩ resistor by the controller and represents the stage negative direction hardware travel limit.
- Encoder A & /A** These A and /A inputs are differential inputs. Signals are compliant with RS422 electrical standard and are received with a 26LS32 differential line receiver. A resistor of 120 Ω adapts the input impedance. The A and /A encoder signals originate from the stage position feedback circuitry and are used for position tracking.

Encoder B and /B	These B and /B inputs are differential inputs. Signals are compliant with RS-422 electrical standard and are received with a 26LS32 differential line receiver. A resistor of 120 Ω adapts the input impedance. The B and /B encoder signals originate from the stage position feedback circuitry and are used for position tracking.
Index & /Index	These Index and /Index inputs are differential inputs. Signals are compliant with RS422 electrical standard and are received with a 26LS32 differential line receiver. A resistor of 120 Ω adapts the input impedance. The Index and /Index signals originate from the stage and are used for homing the stage to a repeatable location.
Encoder ground	Ground reference for encoder feedback.
Origin	This input is pulled-up to +5 V with a 2.2 k Ω resistor by the controller. The Origin signal originates from the stage and is used for homing the stage to a repeatable location.
+5 V (DRV01: 250 mA Maximum)	A +5 V DC supply is available from the driver. This supply is provided for stage home, index, travel limit, and encoder feedback circuitry.
Limit ground	Ground for stage travel limit signals. Limit ground is combined with digital ground at the controller side.
Shield GND	Motor cable shield ground.
Brake + (available only on DRVM board)	Voltage command (24 V or 48 V: strap on the driver board) to drive the brake.
Brake – (available only on DRVM board)	Reference of the above voltage command.
Tachometer + & Tachometer	These inputs are used to receive tachometer voltage information. This voltage depends on the output voltage rating of the employed tachometer.

9.4 Three phase AC Brushless Driver XPS-DRV02



NOTE

Mating connectors:

Male SUB-D9

Female SUB-D9

with UNC4/40 lockers.

MOTOR DRIVER		SERVITUDES	
Pin #	Function	Pin #	Function
1	Phase U	1	+Travel Limit
2	Phase U	2	-Travel Limit
3	Phase V	3	Origin
4	Phase V	4	N.C.
5	Thermistor+	5	+5 V
6	Phase W	6	Thermistor+
7	Phase W	7	GND
8	GND	8	Thermistor-
9	Thermistor-	9	GND

Figure 32: XPS-DRV02 motor driver connectors. The stage thermistor can be connected to either connector.

9.5 DC Motor Driver XPS-DRV03

MOTOR DRIVER 1 TO 4

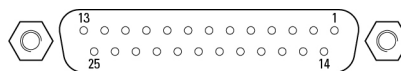

NOTE

Mating connector: Male SUB-D25 with UNC4/40 lockers.

MOTOR DRIVER			
Pin #	Function	Pin #	Function
1	Tachometer+	14	Shield GND
2	Tachometer+	15	Index
3	Tachometer-	16	Limit GND
4	Tachometer-	17	+Travel Limit
5	Motor+	18	- Travel Limit
6	Motor+	19	Encoder A
7	Motor-	20	Encoder B
8	Motor-	21	+5 V
9	N.C.	22	Encoder GND
10	N.C.	23	Encoder /A
11	N.C.	24	Encoder /B
12	N.C.	25	/Index
13	Origin		

Figure 33: XPS-DRV03 motor driver connectors.

9.6 Pass-Through Board XPS-DRV00P



WARNING

The Pass-through board connector replaces the motor interface connector only if the axis is connected to an external motor driver.

PASS-THROUGH BOARD

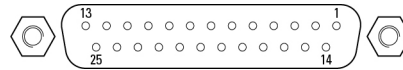

NOTE

Mating connector: Male SUB-D25 with UNC4/40 lockers.

PASS-THROUGH			
Pin #	Function	Pin #	Function
1	Reserved	14	Reserved
2	+5 V	15	Inhibition Output
3	Origin Input	16	Reserved
4	-Travel Limit Input	17	Reserved
5	+Travel Limit Input	18	Reserved
6	Main Fault Input	19	Encoder /A Input
7	Encoder A Input	20	Encoder /B Input
8	Encoder B Input	21	/Index Input
9	Index Input	22	Reserved
10	Pulse/Pulse+ Output	23	GND
11	Direction/Pulse- Output	24	N.C.
12	Analog A Output	25	GND
13	Analog B Output		

Figure 34: DRV00P pass-through connector.

Analog A output and Analog B output have 24-bit resolution at ± 10 V output. These signals are used to command an external driver.



Visit Newport Online at:
www.newport.com

North America & Asia

Newport Corporation
1791 Deere Ave.
Irvine, CA 92606, USA

Sales

Tel.: (800) 222-6440
e-mail: sales@newport.com

Technical Support

Tel.: (800) 222-6440
e-mail: tech@newport.com

Service, RMAs & Returns

Tel.: (800) 222-6440
e-mail: service@newport.com

Europe

MICRO-CONTROLE Spectra-Physics S.A.S
9, rue du Bois Sauvage
91055 Évry CEDEX
France

Sales

Tel.: +33 (0)1.60.91.68.68
e-mail: france@newport.com

Technical Support

e-mail: tech_europe@newport.com

Service & Returns

Tel.: +33 (0)2.38.40.51.55

